

Characterization of Nanosized Al₂O₃ Powder Synthesized by Thermal-Assisted MOCVD and Plasma-Assisted MOCVD

Shizhong, Han^{*†}; Jinghui, Chen; Peng, Zheng; Pang, Qing

Institute of Wuhan Digital Engineering, Wuhan 430074, Hubei, China

ABSTRACT: Nanosized Al₂O₃ powder is synthesized by thermal Metal Organic Chemical Vapor Deposition (MOCVD) combined with plasma. The effects of reaction temperature, pressure, Al(CH₃)₃ (TMA) concentration and reactant gases (CO₂ and O₂) on the characteristics of the synthesized Al₂O₃ powders are investigated. The experimental results demonstrate that very fine Al₂O₃ powders with mean particle size of about 2.5 nm can be obtained at 5.3kPa reactor pressure and 1000 °C by the thermal MOCVD. As the pressure is increased from 5.3kPa to 100 kPa, the mean diameter of Al₂O₃ powders also reaches to 10 nm. In other words, the increase in pressure has a negative effect on the synthesis of nanosized Al₂O₃. Meanwhile, it is also observed that the increment of temperature can promote the synthesis of fine Al₂O₃ powder.

KEY WORDS: Nanosized, Al₂O₃, Thermal MOCVD, Plasma.

INTRODUCTION

Nanosized powders have been attracted much attentions for their wide applications in the electronics and structural ceramics. The nanoscale particles with 0.01 μm below in size have unique properties of superplasticity[1-4] and low sintering temperature. The nanoscale powders can be synthesized by the thermal evaporated condensation using plasma or induction heater, Chemical Vapor Deposition (CVD), spray pyrolysis, Sol-Gel method and milling process. Recently, these manufacturing processes have been intensively studied to found not only the optimum manufacturing conditions but also the synthesis kinetics of nanosized powders. Among these processes, the CVD method is one of the most promising candidates due to the following merits: mass-production, high purity and good size uniformity. During the CVD

process, it has been well known that the nanosized particles can be affected by various processing factors such as reaction temperature, gas specie, pressure and precursor concentration[5-8]. Das et al reported that the synthesis of porous single-phase nanoparticulated α-Al₂O₃ using a dehydrated precursors at low temperature (600°C). The phase-pure nanocrystalline α-Al₂O₃ particles had an average specific surface area of >190 m²/g, with an average pore size between 18 and 25 nm [5]. Janbey et al have also synthesised α-Al₂O₃ particles by pyrolysis of a complex compound of aluminum with triethanolamine and sucrose, and the powder has crystallized sizes of the same order with the average particle size of 20 nm [6]. However, the influence of the synthesis factors has not been cleared yet.

* To whom correspondence should be addressed.

+ E-mail: nlcchust@hotmail.com

1021-9986/11/3/83

6/\$/2.60

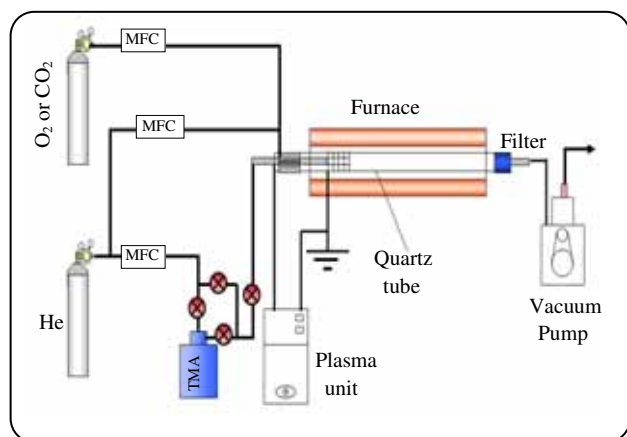

Fig. 1: The schematic diagram of the plasma assisted thermal MOCVD system.

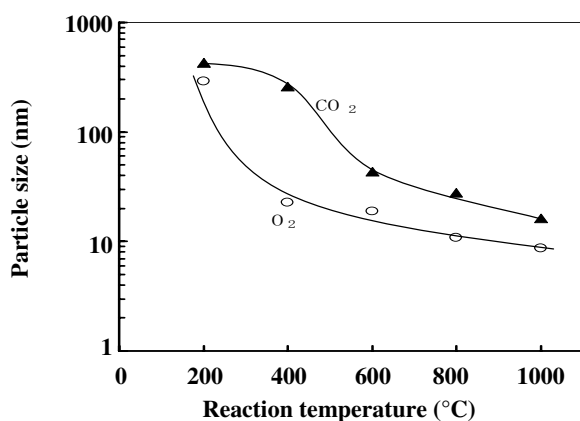

Fig. 2: The average particle size of Al_2O_3 powders synthesized with CO_2 and O_2 reactant gas as a function of the reaction temperatures (reacting pressure: 5.3kPa, TMA concentration: 0.105 mol%).

The aim of the present work is to find the optimum preparation conditions of synthesizing Al_2O_3 nanosized particles by the thermal Metal Organic Chemical Vapor Deposition (MOCVD) method. Hence, the effects of the reaction temperature, the precursor concentration and the reactant gas (CO_2 and O_2) pressure on the properties of Al_2O_3 powders are investigated. In addition, in order to effectively control the particle size of Al_2O_3 powders, plasma is applied in the thermal MOCVD system. Furthermore, the comparison of in the presence and absence of plasma combined with thermal MOCVD are performed.

EXPERIMENTAL SECTION

The nanosized Al_2O_3 particles are prepared by the tube type thermal MOCVD system, which is consisted of bubbler, thermal reactor and filters. In the thermal

MOCVD method assisted with plasma (herein-after called as "plasma reaction"), the nonequilibrium plasma is generated by a DC pulse discharge. During the plasma reaction, the gas discharge is occurred intermittently by 7.5kV high voltage DC pulse to avoid arch discharge. In the case of the thermal MOCVD method without plasma (herein-after called as "thermal reaction"), the plasma chamber is detached from the MOCVD system.

Fig. 1 shows the schematic diagram of the thermal MOCVD system assisted with plasma. During the preparation process, the raw material, TMA ($\text{Al}(\text{CH}_3)_3$) is bubbled and poured by He carrier gas with a flow rate of 50cc/min, and the concentrations range of TMA is 0.011 mol%-0.182 mol%. The flow rate of delivered O_2 (or CO_2) gas in the reactor is about 200 cc/min. The other reaction conditions vary from 200 °C to 1000 °C in the reaction temperature and from 5.3 kPa to 100 kPa in pressure. Finally, the synthesized Al_2O_3 powders are collected at attached micro-filters, then the crystalline phases are identified by X-Ray Diffraction (XRD). The powder morphologies and crystallite size are also examined by the Transmission Electron Microscopy (TEM) observation.

RESULTS AND DISCUSSIONS

Thermal reaction

Fig. 2 shows the temperature dependence of the average particle size of Al_2O_3 powders synthesized with CO_2 and O_2 reactant gas, the temperature range is 200- 1000 °C. It indicates that the average particle size of Al_2O_3 powders is decreased remarkably with increasing reaction temperatures when the temperature is below 600 °C, then the temperature only has slight influence on the particle diameter, which means the increment of temperature can promote the formation of nanoscale Al_2O_3 powders. In the case, the particle diameter varies from 10 nm to 400nm. Moreover, the average particle size of Al_2O_3 powders synthesized with CO_2 gas is larger than that with O_2 gas, the reason of this phenomena is still unknown.

Fig. 3 shows the average particle sizes profile of Al_2O_3 powders (TMA concentration: 0.105 mol%) synthesized at (a) 200 °C and (b) 1000 °C as function of pressure. In both of the cases, pressure has negative effect on the preparing nanoscale Al_2O_3 particles, especially at the pressure range of 5 kPa-40 kPa, acute variation of particle diameter is occurred. When Al_2O_3 powders are synthesized at 1000 °C using O_2 gas, the average particle

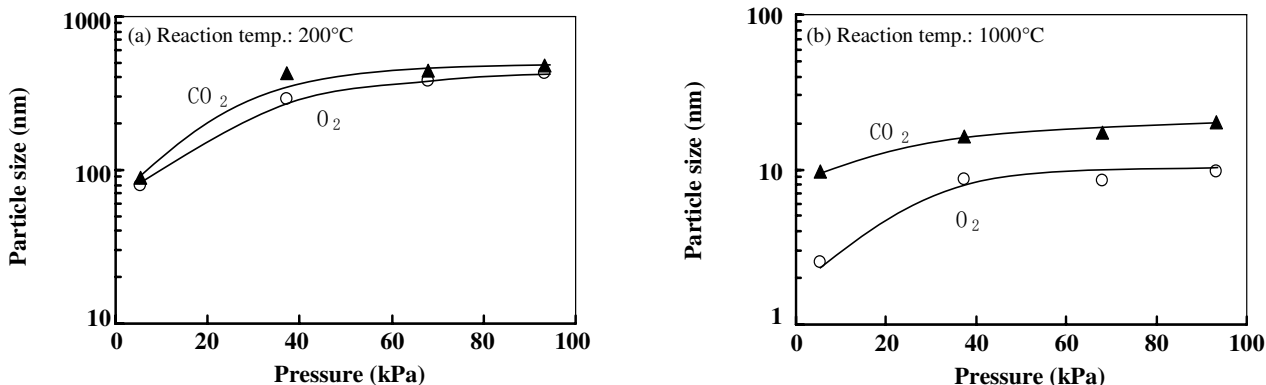

Fig. 3: The average particle size of Al₂O₃ powders reacted at (a) 200 °C and (b) 1000 °C according to the reaction pressures depending on the reactant gas (TMA concentration : 0.105 mol%).

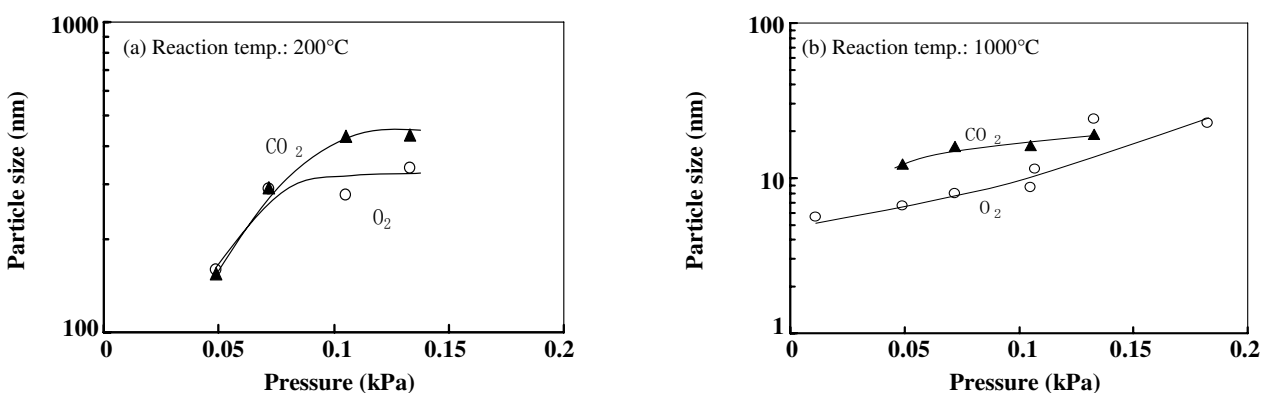

Fig. 3: The average particle size of Al₂O₃ powders reacted at (a) 200 °C and (b) 1000 °C according to the reaction pressures depending on the reactant gas (TMA concentration : 0.105 mol%).

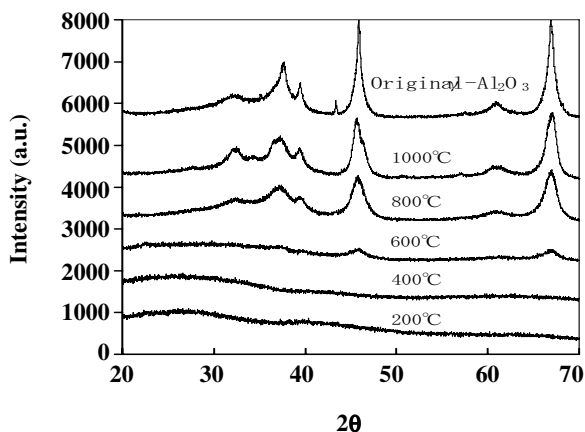

Fig. 5: X-ray diffraction pattern of Al₂O₃ particles depend on reaction temperature.(reaction pressure: 5.3kPa, TMA concentration : 0.105 mol%)

size is very fine, even as fine as 2.5 nm particles can be obtained at the pressure of 5.3 kPa. The size is the smallest crystallite synthesized in this experiment.

The effect of TMA concentrations on the particle size of Al₂O₃ powders is also demonstrated in Fig. 4. In the case of 200 °C, the negative effect of TMA concentration on the average particle size of Al₂O₃ powders (reacting pressure: 5.3kPa) is remarkable until TMA concentration is above 0.1 mol%, then the Al₂O₃ particle size is independent of TMA concentrations. While in the case of 1000 °C, the concentration of TMA always has linear effect on the particle diameter. The average particle size of powders synthesized at 1000 °C with O₂ gas has a minimum value of 5.6nm at the concentration of 0.049mol%. Based on the experimental results, it can be concluded that the nanosized Al₂O₃ powders with the size of 2.5nm~8.7nm can be obtained at the following reaction condition: The reactant gas is O₂; The temperature is about 1000 °C; The pressure and the TMA concentration are 5.3kPa and 0.049 mol% , respectively.

The X-ray diffraction patterns of nanosized alumina powders synthesized at 200 °C -1000 °C are represented in Fig. 5. The XRD analysis shows the synthesized Al₂O₃

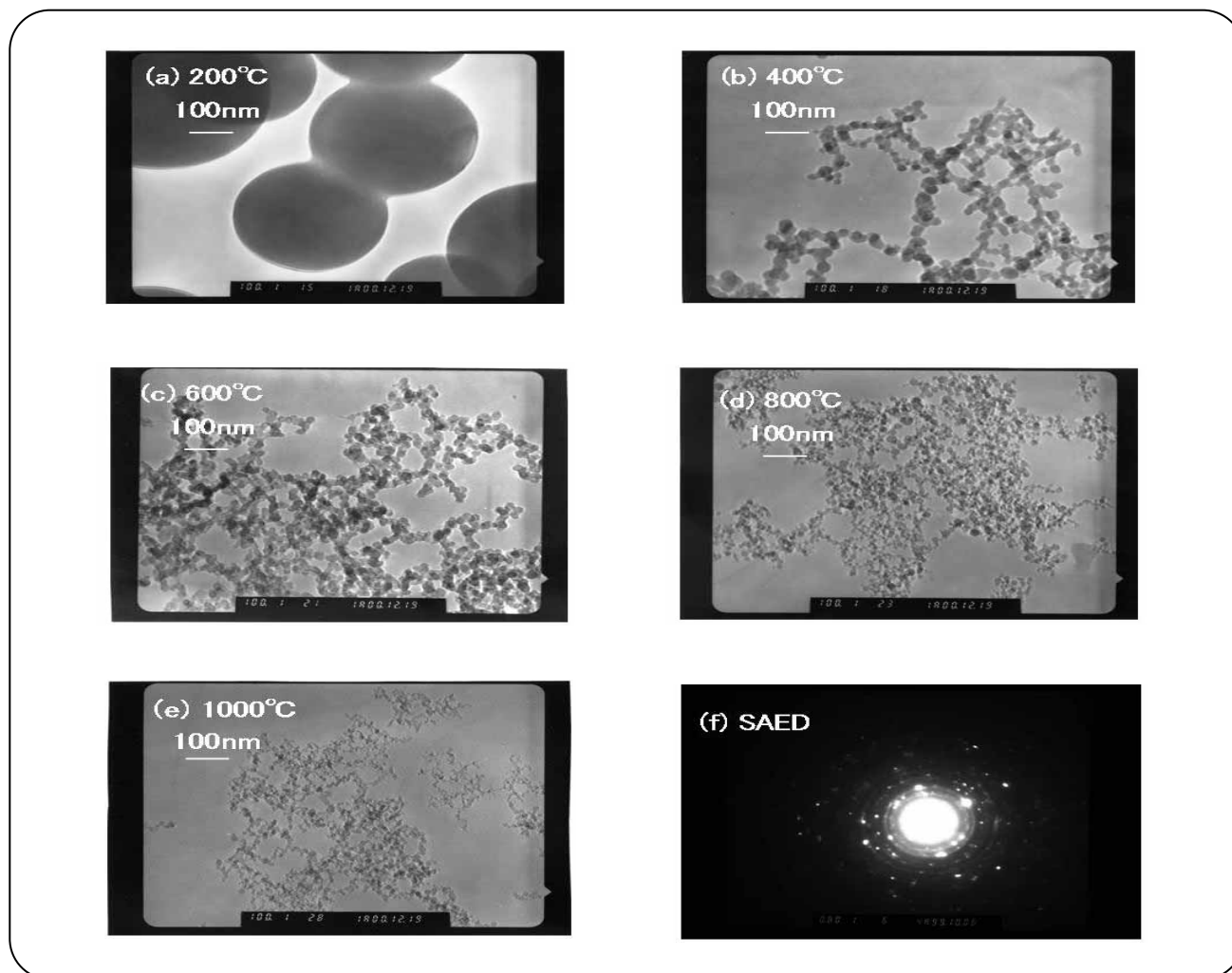

Fig. 6: TEM image of Al_2O_3 powders synthesized at different temperature and (e) selected area electron diffraction(SAED).

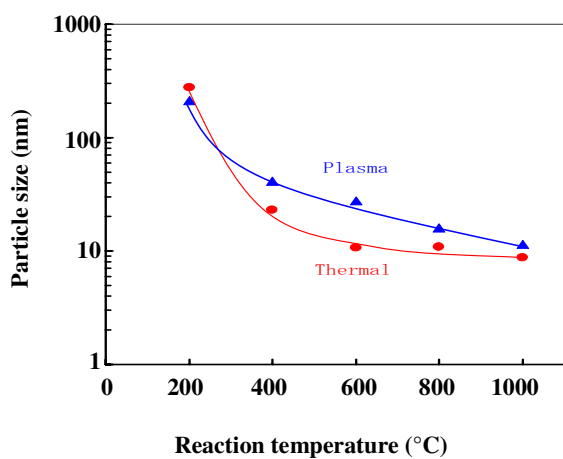

Fig. 7: The average particle size of Al_2O_3 powders synthesized by the thermal and the plasma reactions using reactant O_2 gas at the various reaction temperatures (reacting pressure: 5.3kPa, TMA concentration: 0.10 5mol%).

powders is typical $\gamma\text{-Al}_2\text{O}_3$ crystalline phases when the reaction temperature is above 800 °C.

Fig. 6 demonstrates the morphologies and crystallite of Al_2O_3 powders synthesized at different temperature. The synthesized particle is nearly spherical shape. Meanwhile, the Selected Area Electron Diffraction (SAED) spots reveal that these nanoparticles are all single crystalline. Furthermore, it is also found the particle diameter decrease with the enhancement of temperature, which is consistent with above conclusion.

Plasma reaction

Fig. 7 presents the variation of Al_2O_3 particle size versus different reaction temperature (200 °C -1000 °C) in the plasma reaction. The reactant is O_2 gas and the pressure is under 37kPa. The experimental results

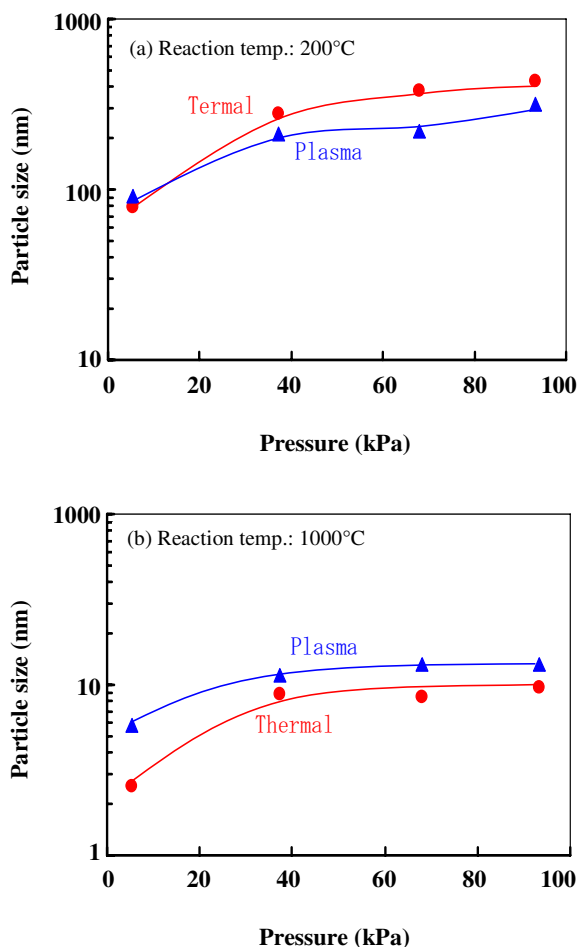

Fig. 8: The average particle size of Al_2O_3 powders synthesized at (a) 200 °C and (b) 1000 °C depending on the thermal reaction and the plasma reaction at various pressures (TMA concentration : 0.105mol%).

demonstrate that the average particle size of Al_2O_3 powders is also decreased with increasing reaction temperatures. The average particle size of Al_2O_3 powders synthesized by plasma reaction at 200 °C is about 212 nm. As the reaction temperature is increased to 400 °C, the average size is sharply decreased to 41.6 nm. After comparing the two case of thermal reaction and plasma reaction, it is found the particle size in the case of plasma reaction is slightly larger than that of Al_2O_3 powders synthesized by the thermal reaction when the reaction temperature is above 200 °C. The phenomena is attributed to powder agglomeration occurred in the process of preparing Al_2O_3 powders by the CVD system combined with the plasma. Hence, it can be concluded that the plasma has a negative effect on synthesis Al_2O_3 powders by CVD method

The pressure dependence of average particle size of Al_2O_3 powders (0.105 mol% TMA, O_2 gas) in both of thermal and the plasma reactions are shown in Fig. 8((a) (b) means the Al_2O_3 powders synthesized at 200 °C and 1000 °C, respectively). Same to the situation in thermal reaction, Al_2O_3 powders size also declines with the increase of pressure in plasma reaction. Plasma reaction is more effective than thermal reaction in preparing nanoscale Al_2O_3 powders at 200 °C. However, thermal reaction is better when temperature is higher than 200 °C.

CONCLUSIONS

The effects of the reaction temperature, pressure and TMA concentration on the properties (average particle size) of the nanosized Al_2O_3 powders synthesized by the thermal MOCVD are investigated. Based on the experimental results, the following conclusions are obtained:

The average particle size of the powders is decreased with increasing the reaction temperature and decreasing the pressure;

The average particle size of Al_2O_3 powders synthesized with CO_2 reactant gas is larger than that with O_2 gas;

The synthesized Al_2O_3 powders is typical $\gamma\text{-Al}_2\text{O}_3$ crystalline phases when the reaction temperature is above 800 °C;

The synthesized particle is nearly spherical shape;

The plasma has a negative effect on synthesis Al_2O_3 powders by CVD method.

Received : July 29, 2009 ; Accepted : Nov. 24, 2010

REFERENCES

- [1] Li H., Lu H., Wang S., Jia J., Sun H., Hu X., Preparation of a Nano-Sized $\alpha\text{-Al}_2\text{O}_3$ Powder from a Supersaturated Sodium Aluminate Solution, *Ceram. Int.*, **35**, p. 901(2009).
- [2] Sarkar D., Mohapatra D., Ray S., Bhattacharyya S., Adak S., Mitra N., Synthesis and Characterization of Sol-Gel Derived ZrO_2 Doped Al_2O_3 Nanopowder, *Ceram. Int.*, **33**, p. 1275 (2007).
- [3] Kulkarni N.V., Karmakar S., Banerjee I., Sahasrabudhe S.N., Das A.K., Bhoraskar S.V., Growth of Nano-Particles of Al_2O_3 AlN and Iron Oxide with Different Crystalline Phases in a Thermal Plasma Reactor, *Mater. Res. Bull.*, **44**, p. 581 (2009).

- [4] Bernardo E., Colombo P., Hampshire S., Advanced Ceramics from a Pre ceramic Polymer and Nano-Fillers, *J. Eur. Ceram. Soc.*, **29**, p. 843 (2009).
- [5] Das R.N., Bandyopadhyay A., Bose S., Nanocrystalline α -Al₂O₃ Using Sucrose, *J. Am. Ceram. Soc.*, **84**, p. 2421(2001).
- [6] Janbey A., Pati R.K., Tahirc S., A New Chemical Route for the Synthesis of Nano-Crystalline α -Al₂O₃ Powder, *J. Eur. Ceram. Soc.*, **21**, p. 285 (2001).
- [7] Das R.N., Pramanik P., Preparation of Nanocrystalline α -Al₂O₃ Using Plant Fiber, *J. Nanosci. Nanotechno.*, **4**, p. 94 (2004).
- [8] Park J.H., Lee M.K., Rhee C.K., Control of Hydrolytic Reaction of Aluminum Particles for Aluminum Oxide Nanofibers, *Mater. Sci. Eng.*, **375-377**, p. 1263 (2004).