

# Preparation of Expandable Polystyrene by Multi-Stage Initiator Dosing/Styrene-Butadiene-Styrene Blends with Application of Artificial Neural Networks

*Ghazanchaie, Samira; Derakhshanfard, Fahimeh\*<sup>+</sup>; Amirkhani, Leila*

*Department of Chemical Engineering, Ahar Branch, Islamic Azad University, Ahar, I.R. IRAN*

**ABSTRACT:** *Expandable Polystyrene (EPS) is one of the most used polymers. Preparation of this polymer by the conventional method has some problems which cause the synthesis process to be difficult and also decrease the quality of the prepared EPS. In this study, Styrene-Butadiene-Styrene (SBS) has been added to improve some properties of the prepared polymer and the Multi-stage Initiator Dosing (MID) method has been used to reduce the time of the polymerization which causes the polymer's production capacity to increase. SBS has been added to EPS in shares of 2%wt, 4%wt, and 6%wt. The polydispersity index (PDI) test and the amount of tension in the yield point of the polymer have been checked. The amount of absorbed pentane on the polymer studied. The amount of residual monomer on the polymer has been investigated. All of the studies happened under different conditions like different percentages of initiator, different numbers of dosings, and different time periods of the first stage of the polymerization. Experimental data have been simulated by Multi-Layer Perceptron (MLP) and Radial Basis Function (RBF) methods of Artificial Neural Networks (ANN). The performance of the simulation for RBF method was better in comparison to MLP method due to having a strong scientific foundation and also the ability to filter noises. The experimental data show that a higher amount of SBS causes improvement in properties like elongation at break, better pentane absorption, and PDI amount has improved, which shows the better distribution of molecular weight and a decrease in residual monomer in products.*

**KEYWORDS:** *Expandable Polystyrene (EPS); Styrene-Butadiene-Styrene (SBS); Multi-stage Initiator Dosing (MID); Multi-Layer Perceptron (MLP); Radial Basis Function (RBF).*

## INTRODUCTION

The applications of EPS having SBS blends can be very important because of having better performance compared to EPS [1]. EPS has always been an important material because of its special properties which can be used in many fields [2, 3]. Now, by adding SBS to the EPS, these properties can be optimized and by ANN the prediction of values is possible and very helpful because of reducing

the number of tests needed to obtain data [4, 5].

Expandable polystyrene (EPS) is a polymer with wide applications in many fields. The necessity of EPS in nowadays industries is undeniable. EPS has wide usage in construction, packaging, insulating, and many other industries because of excellent properties like thermal insulation, moisture resistance, shock absorption and

---

\* To whom correspondence should be addressed.

+ E-mail: f.dfard@gmail.com

1021-9986/2022/6/1961-1975

15/\$/6.05

so on [6- 9]. Polystyrene foam is produced by expanding the expandable polystyrene beads. Expandable polystyrene is formed from a styrene polymer network including pentane in a suspension polymerization process and styrene gain a polymeric structure [10, 11]. In the conventional method of EPS production, two different initiators having two different levels of temperature are used and all the materials have entered the reactor at the first stage of the batch [12]. The problems with this method are long duration and difficult control of the polymerization process. In order to not have these problems, the Multi-stage Initiator Dosing (MID) method has been used. In MID method the initiator of the first stage enters the reactor in several injections and at higher temperatures than in the conventional method [13].

Nowadays the use of Styrene-butadiene-Styrene (SBS) as an additive to other products is greatly increased [14- 16]. SBS improves the performance of many products like asphalt binders, PCL, etc. It has been shown that a new intelligent polymer with Shape Memory Effect (SME) has been made by PCL and SBS from an immiscible blend [17, 18]. SBS/(5 graphenes) fiber revealed the widest workable strain range of nearly 250% and the highest sensitivity at large strains [19]. The results of a study showed that the best performance of unaged composites is 20% (Poly Propylene)/SBS and a Low-temperature test combined with dynamic thermal analysis found that the addition of SBS effectively improved the low-temperature brittleness of polypropylene composites without added compatibilizer [20]. The performance of a polymer-modified binder increased with SBS content and it is found that both instantaneous modulus and viscosity increase with the SBS content [21]. The fabricated SBS showed slightly lower water flux than the polytetrafluoroethylene membrane because it was two times thicker and the SBS membrane had better salt rejection and most importantly could be fabricated *via* a simple process. In addition, the SBS membrane had superior mechanical strength over the poly tetra fluoro ethylene membrane [22].

Predicting data can be very helpful because of reducing the number and materials of the test needed to collect data. Artificial Neural Networks is a simulation that can predict data for the points that have not been tested. Radial Basis Function (RBF) and Multi-Layer Perceptron (MLP) are the most popular methods of ANN [23-26]. ANN is one of the major branches of artificial intelligence,

consisting of massively interconnected nonlinear memoryless processing elements known as neurons or nodes [27]. An ANN was used to identify quantum phase transitions from single-shot experimental momentum-space density images of ultracold quantum gases and obtain results that were not feasible with conventional methods. The networks of the two examples of the Bose–Hubbard system and the Haldane system have been compared and found that applying the network trained on one example to the data from the other example gives a definite result [28]. In research, in order to predict different parameters by learning (ANN) with collected data from a viscometer by which nanofluid's viscosity has been measured, general performances of RBF ANN are used. With (RBF-ANN) method, the connection between 3 known parameters has been revealed in different conditions [29]. Multi-Layer Perceptron (MLP) with the back-propagation method and neural network software (i.e., Matlab) were used for the Differential Thermal Analysis (DTA) prediction of Water Expandable Poly Styrene (WEPS), The results show that there is a good agreement between predicted thermal behavior and the actual values [30]. In research, PET Waste in different weight percentages has been combined with ABS under different conditions of temperature, time, and speed of extruder in order to reuse PET and reduce environmental problems. The results declared that in conditions with constant temperature and time and speed of mixing with increasing PET Waste in ABS, the properties of this polymer have been improved. Also, the results of the simulation covered the laboratory data perfectly [31].

Much research has been done in the field of using artificial neural networks for polymer data. But unfortunately, there is no research in the field of using ANN for expandable polystyrene data except one that has been explained in the below paragraph [32-37].

Synthesis of expandable polystyrene by initiator dosing method has been accomplished in this study, the ratio of tension to strain for different conditions like different times of the polymerization and different amount of the reduced initiator, and different times of dosings has been investigated and the laboratory results have been studied by artificial neural networks and the predicted values covered laboratory data perfectly [37].

In this study, MID method for synthesis of the EPS has been used. In order to improve the quality of the EPS,

**Table 1: the used materials for the synthesis of EPS/SBS.**

Materials	specification	CAS number	Manufacture
Styrene	99.7% Pure	100-42-5	Tabriz Petrochemical Company
Pentane	99% Pure	109-66-0	Tabriz Petrochemical Company
Styrene-Butadiene-Styrene (SBS)	-	9003-55-8	Arak Petrochemical Company
Calcium Phosphate	Mw= 310.18g/mol	7758-87-4	Merck
Polyvinyl Alcohol	Mw=47000 and 98% hydrolyzed)	9002-89-5	Merck
Benzoyl Peroxide	-	94-36-0	Merck
Tert-Butyl Benzoyl Peroxide	-	614-45-9	Merck
Deionized Water	-	7732-18-5	Tabriz Petrochemical Company

SBS have been used as an additive. Four important characterizations of EPS (PDI, the absorbed pentane percent, the amount of the tension in yield point, the amount of the residual monomer in different percentages of the initiator, different times polymerization of the first stage, and the number of different dosings) has been studied. The data gained from the laboratory has been simulated by ANN. RBF and MLP methods of ANNs have been used and compared for the simulation.

## EXPERIMENTAL SECTION

### Materials

Styrene as a monomer, pentane as a blowing agent, styrene butadiene styrene as an additive for improving the quality of the final product, calcium phosphate, and polyvinyl alcohol as a suspension agent, benzoyl peroxide and tert-butyl benzoyl peroxide as initiator, and deionized water have been used as suspension media and all of them has been shown in Table 1.

### Equipment

As shown in Fig. 1, a 5 L stainless steel Buchi reactor has a discharge valve at the bottom, There are two baffles on each side of the stirrer with 8 cm distance of walls. baffles and hot oil jacket controlled thermostatically with two three-blade mixers. The diameter of the stirrers is 15 cm and the distance between them is 10 cm and the distance of the lowest stirrer from the bottom of the reactor is 15 cm. Initiator is injected in to the reactor at desired time intervals by a dosing pump. For determination of the percentage of pentane absorbed and the concentration of the monomer remaining in the sample, Varian 3800CP Gas Chromatographer has been used. Testing was conducted

in accordance with ASTM 5135. Zwick Roll (model TI- FR010THA50) Germany according to ASTM 1621, has been used to determine the mechanical strength of the prepared blocks.

### Preparation of Styrene Butadiene Styrene (SBS)

SBS with 2% wt, 4% wt, and 6 %wt styrene monomer has been dissolved in styrene and stirred by a mechanical stirrer with a speed of 350 rpm until complete dissolution.

### Preparation of benzoyl peroxide (Initiator)

Benzoyl Peroxide entered the reactor in a different number of dosings (6 dosings, 8 dosings, 10 dosings, 12 dosings) while the reactor is closed, and the temperature of the reactor is 110°C. Therefore, this powder is needed to prepare as suspension, so benzoyl peroxide was dissolved in styrene and prepared as a suspension in order to be injected into the reactor by a dosing pump.

### Multi-stage initiator dosing method

2.4 kg of water is charged into the 5 L reactor. Then, 5.6 g Calcium Phosphate and 1 kg styrene monomer are added to the reactor and the mixture is stirred at 360 rpm the heating of the reactor starts when the temperature of the reactor reached 40°C. SBS with different percentages (32, 64, 96 g dissolved in 300g styrene) is added to the reactor. The reactor temperature reaches 40°C with a rate of 1.083 °C/min. usually, the initiator, with different weight percentages (5.93, 4.74, 4.44, 4.131 gr dissolved in 300 g styrene monomer) and in different numbers of dosings (6 dosings, 8 dosings, 10 dosings, and 12 dosings) and at the same interval, enters the reactor. After 1 hour, the reactor temperature reaches 110°C, and stage one polymerization

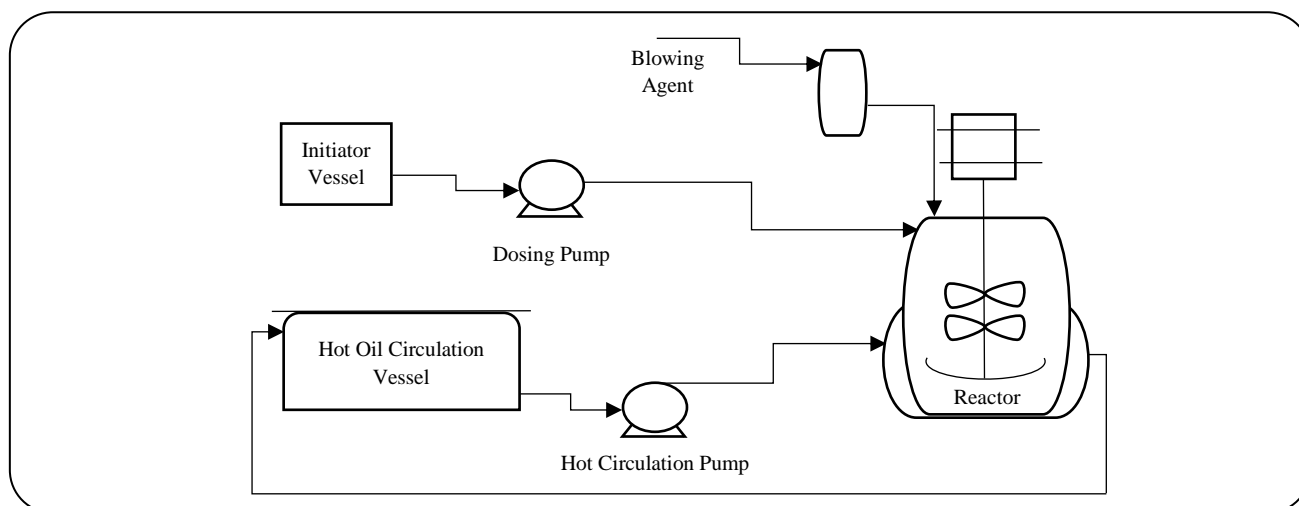

Fig. 1: Polymerization setup for MID EPS Synthesis.

in different times (4 hours, 3.5 hours, 2.5 hours, 2 hours) is done. At the end of the first stage of polymerization with an increase in temperature to 122 °C, 128 g pentane and 2.26 g tert butyl benzoyl peroxide as an initiator in the second stage are added to the reactor. Stage two polymerization takes 2 hours to complete, the temperature of this stage is 122 °C and the pressure is 7 bar. After this stage, the reaction mixture of the polymerization cooled down.

#### Artificial Neural Networks (ANN)

In this article, the performance of Multi-Layer Perceptron (MLP) and Radial Basis Function (RBF) methods of Artificial Neural Networks (ANN) regarding the prediction of the different parameters through mentioned networks learning with collected data from a Buchi reactor on a laboratory scale is compared.

The number of neurons in RBF networks is equal to the number of laboratory data, therefore, for better comparison with MLP networks, in all items, the number of neurons for MLP networks is set to equal to laboratory data.

The regularization network was completely self-sufficient and did not require any initial values for its linear and non-linear parameters. RBF networks use all the input data as their centers and in each item, the internal optimization method for isotropic width selection (6) is used separately. The Leave One Out Cross Validation (LOOCV) criterion is used for the determination of the optimal value of the regularization parameter. In contrast, the performance of MLP networks is completely dependent on the initial value of their synaptic weight ratios. In performed simulations in this article, firstly different initial values for

Synaptics have been used and then the best response among them has been selected.

The used data referred to mentioned ANN learning, is the result of the multiple experiments which investigates elongation at break, the amount of absorbed pentane, residual monomer, and PDI value for prepared polymer by the Multi Initiator Dosing (MID) method.

#### RESULTS AND DISCUSSION

In order to improve the quality of the developed EPS by the Multi-stage Initiator Dosing method, Styrene Butadiene Styrene (SBS) was added to the reactor in different percentages (0.2, 0.4, and 0.6) before the polymerization begin.

The 4 important characterizations of this polymer include PDI, the absorbed pentane percent, the amount of tension in the yield point and the amount of the residual monomer in different percentages of the initiator, different times polymerization of the first stage, and the number of different dosings has been studied.

In MID method of production of the EPS, the consumption of the initiator is reduced in comparison with the conventional method and the initiator with 20, 25, 30 percentages of reduction, and the time of the first stage of the polymerization in 4, 3.5, 3, 2.5 hours had been investigated. By assuming the 4 hours as the basic time in figures, in the form of reduced times related to 4 hours in 4 different states (0.125, 0.25, 0.375) investigated and the number of different initiator dosings (6, 8, 10, 12) that which in figures by assuming 12 times as the basis in the production of this polymer by MID method, time reduction has been shown as (0.5, 0.33, 0.167, 0).

### Poly Dispersity Index (PDI)

In Figs. 2 to 4 different percentages of SBS were investigated. In all 3 figures with an increase in the amount of the SBS, the amount of the PDI decreases. With increasing the amount of the SBS, the amount of the PDI approaches number 1 and shows a better distribution of the molecular weight. In fact, with increasing SBS, in terms of molecular weight, EPS polymers are corrected. Reduction of the initiator and reduction of the number of dosings a constant amount of the SBS, results in decreasing molecular weight, and by its very nature, it decreases PDI too due to a reduction of the length of the polymeric chain, but the reduction in time of the polymerization causes PDI to increase. In Fig. 2, PDI in different percentages of reduction of the initiator is investigated. As shown in the figure, when the reduction of the initiator is 0.3 and 0.25, the decrement of the PDI with increasing the percentages of the SBS is very minor, but for 0 and 0.2 percentages this decrement is impressive.

In Fig. 3 it has been shown that the decrement of the PDI for different time points of the polymerization happened with the same gradient.

Fig. 4 showed that a change in the number of dosings of the initiator has a little different for the PDI.

### The absorbed pentane percent

Figs. 5 to 7 investigate absorbed pentane percent in different percentages of SBS. With increased percentages of SBS in EPS, the amount of absorbed pentane is reduced. Since the appropriate range for the absorbed pentane for EPS are between 4 and 6 percent, therefore for all the charts between 2 to 4 wt%, SBS has the best range in all conditions in terms of pentane absorption.

Decreasing the initiator percent and numbers of the dosing and increasing the polymerization time, in the constant percentage of SBS, due to proper makeup of the polymeric chains, cause high pentane absorption.

In Fig. 5, which shows absorbed pentane in different percentages of SBS and reduced initiator, increasing the percentage of SBS, chart of the initiator reduce for zero percentage of reduction for initiator with an almost slower slope proportional to the other percentages of the initiator.

Absorbed pentane in different percentages of SBS and reduced times of polymerization have been shown in Fig. 6. With increasing SBS, the slope for the charts of the reduced times of the polymerizations reduces identically.

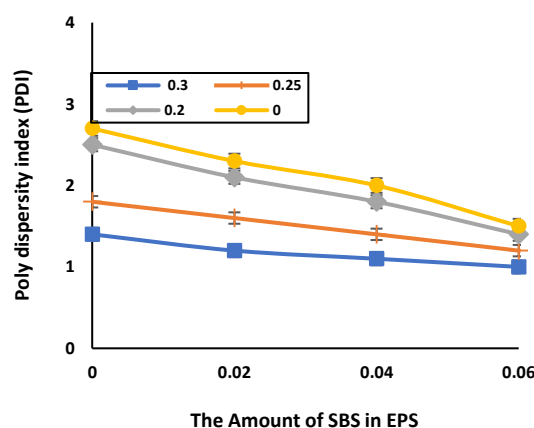

Fig. 2: Results of PDI at different percentages of SBS in EPS and different percentages of the initiator of Reduction.

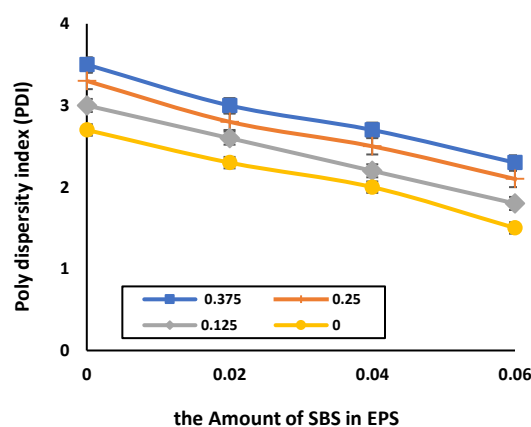

Fig. 3: Results of PDI at different percentages of SBS in EPS and different times polymerization of the first stage.

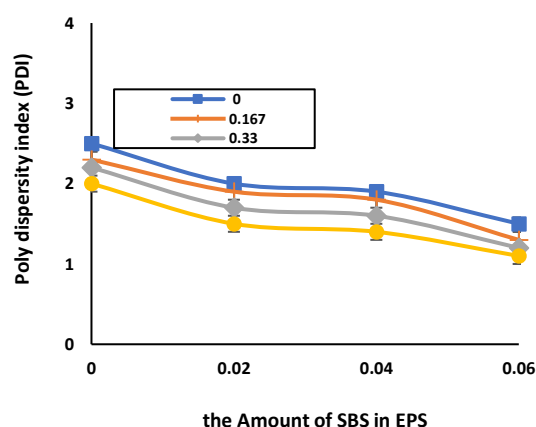

Fig. 4: Results of PDI at different percentages of SBS in EPS and number of different dosings.

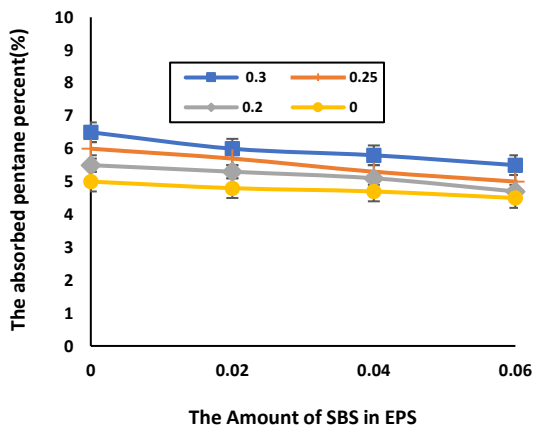

Fig. 5: The absorbed pentane percent at different percentages of SBS in EPS and different percentages of initiator of Reduction.

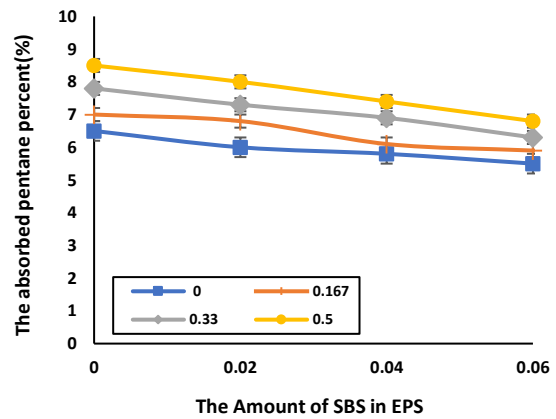

Fig. 7: The absorbed pentane percent at different percentages of SBS in EPS and number of different dosings.

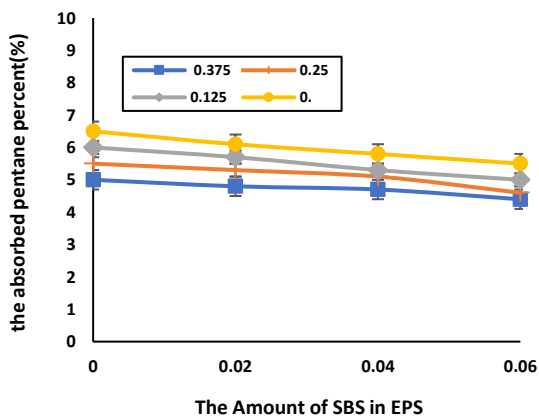

Fig. 6: The absorbed pentane percent at different percentages of SBS in EPS and different times polymerization of the first stage.

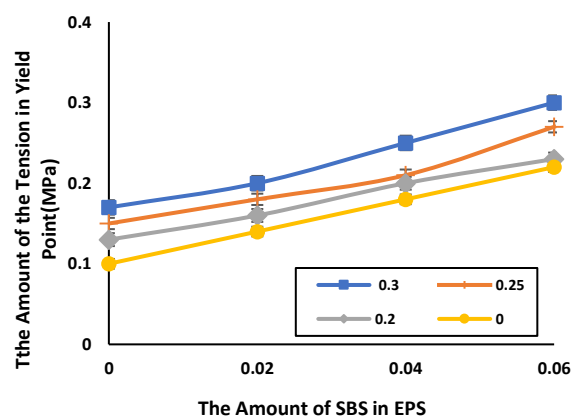

Fig. 8: The amount of the tension in yield point at the amount of SBS in EPS and reduced initiator percent.

In Fig. 7, which shows absorbed pentane in different percentages of SBS for different numbers of dosings, for a state with 12 times of dosings, the slope of the decrement chart is slower in comparison to other states.

#### The amount of the tension in yield point

Study results of the stress in yield point in Figs. 8 to 10 are investigated. As specified from the charts, with increasing SBS, the amount of tension in the yield point increase for all states. In fact, the increasing amount of SBS, elongation at break for EPS polymer is increased.

Reducing the initiator and increasing the time of the polymerization and the number of doings in a constant amount of the SBS cause increasing the amount of the tension in yield point.

Therefore, for increasing elongation at the break of the polymer, using an initiator in 70%, the first stage of the polymerization in 4 h and 12 number of doings is recommended while the percentage of SBS in EPS equals 6 percent.

Fig. 8 shows the amount of the tension in yield point for different percentages of SBS in different percentages of the initiator. The increment range for the tension with an increase in SBS for all percentages of initiators is about the same.

The amount of the tension in yield point for different percentages of SBS in EPS for different times of polymerization is shown in Fig. 9. The changes range for the decrease in time (0.375) happen with uniform slope while for other time decrements with increasing the percentage

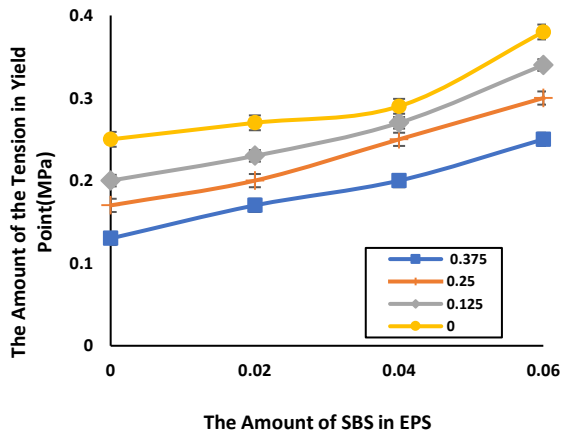

Fig. 9: the amount of the tension in yield point at the amount of SBS in EPS and polymerization time of the first stage.

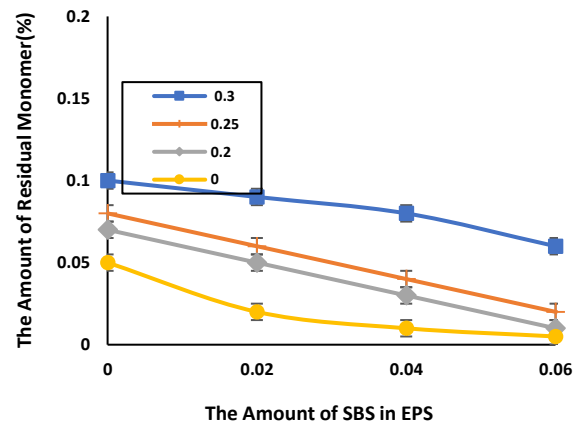

Fig. 11: The amount of residual monomer at the amount of SBS in EPS and reduced initiator percent.

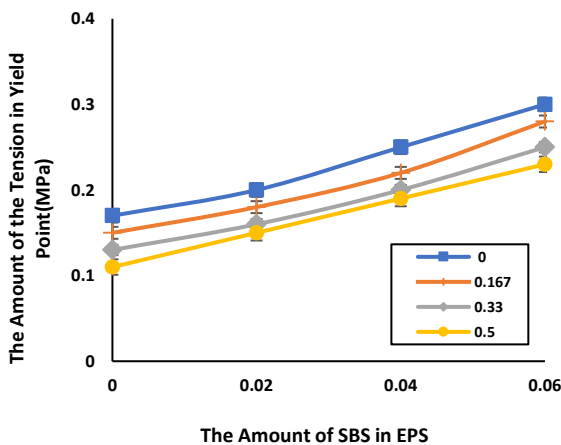

Fig. 10: the amount of the tension in yield point at the amount of SBS in EPS and number of dosings.

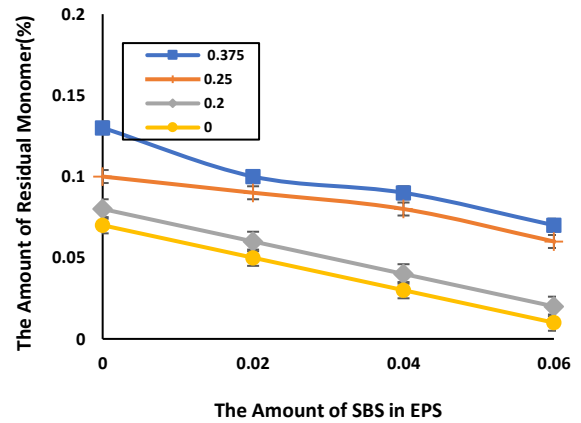

Fig. 12: The amount of residual monomer at the amount of SBS in EPS and polymerization time of the first stage.

of polymerization, there are different behaviors. The highest level of elongation at break is the state with 4 h of polymerization time in 6 percent of SBS in EPS.

Investigation of the amount of the tension in yield point for different dosings number with different percentages of SBS are shown in Fig. 10. increase of the amount of the tension in yield point for each one of the states happen with the same slope and the maximum level is the state with 12 dosings.

In addition, with the change in the number of dosings, there is no impressive change in stress level in the yield point.

#### The amount of residual monomer

The amount of residual monomer in different percentages of SBS in EPS for different percentages of

initiator is shown in Fig. 11. The amount of residual monomer in different percentages of SBS in EPS for different times of polymerization is shown in Fig. 12. The amount of residual monomer in different percentages of SBS in EPS for a different number of dosings is shown in Fig. 13. With the increase in the percentage of SBS, the amount of residual monomer decreases for every state.

A study of the charts declares that for constant SBS, decreasing the initiator and time of the polymerization, and the number of dosings causes the amount of the residual monomer to increase. Therefore, for having the minimum amount of residual monomer, the state with the maximum amount of initiator (100%), 4 h of polymerization time, and 12 number of dosings is recommended.

Figs. 14 and 15 are microscopic pictures of the prepared polymer by conventional and initiator dosing methods with 150\* zoom. By investigating the pictures, it has been declared that while the initiator dosing method has higher pentane absorption and created holes are bigger, it has a more uniform distribution of the seeds.

#### Results of simulation with Artificial Neural Networks

The data gained from the laboratory has been simulated by Artificial Neural Networks (ANN). Radial basis function (RBF) and Multi-Layer Perceptron (MLP) methods of ANNs have been used for the simulation. In case of having good cover for laboratory data by simulation, it can be used for obtaining results for points that have not been tested.

Fig. 16 has shown the results for RBF and MLP methods of ANN for investigating PDI in different percentages of SBS in EPS, for different percentages of initiators and different times of the first stage polymerization, and for a different number of dosings.

The results of different percentages of initiator have been reduced and the results of different times of the first stage polymerization for RBF and MLP are close. The results of the simulation show that the simulated data fit the laboratory data but for the match state, the number of surface initiator dosings by MLP method is not uniform and has more oscillation in comparison with RBF network because of good reduction of the noises by RBF method, it works better in compare to the MLP method. But both methods cover the laboratory data.

Studying the amount of the absorbed pentane in different percentages of SBS in EPS for a different amount of initiator, the times of the first stage polymerization, and a different number of dosings have been shown in Fig. 17.

The results of RBF and MLP methods of ANNs are about the same for each of the figures and both RBF and MLP figures can be used for prediction in points in which the experiment is not done.

Fig. 18 shows the tension in yield points for different percentages of SBS in EPS. For Fig. 16-a which is related to different percentages of initiators for RBF and MLP methods, there is the only difference in a little area of the surface and the total figure declares a good prediction of the simulation.

Fig. 18-b investigates the time of the first stage of polymerization, the MLP method has some noise but the RBF method has better performance due to having a strong scientific foundation and the ability to filter noises.

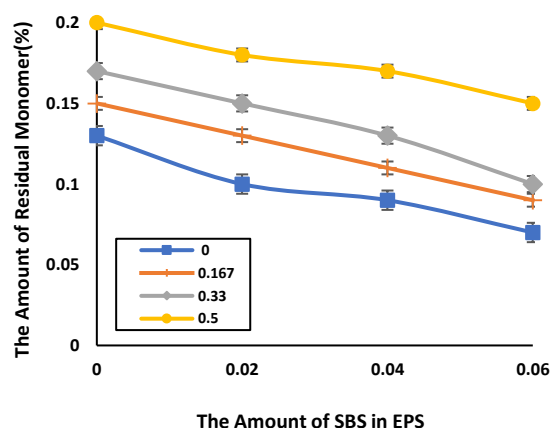

Fig. 13: The amount of residual monomer at the amount of SBS in EPS and number of dosings.

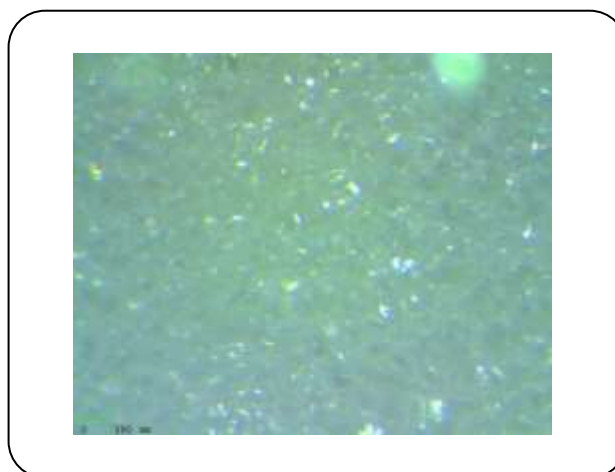

Fig. 14: Microscopic image of EPS produced using the conventional method (150X magnification)[38].

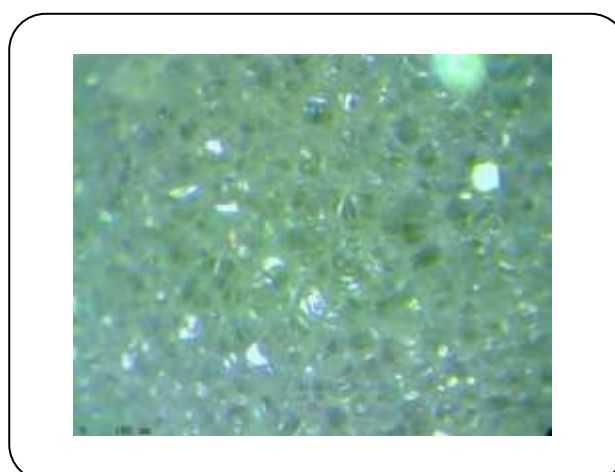

Fig. 15: Microscopic image of EPS produced using MID (150X magnification)[38].



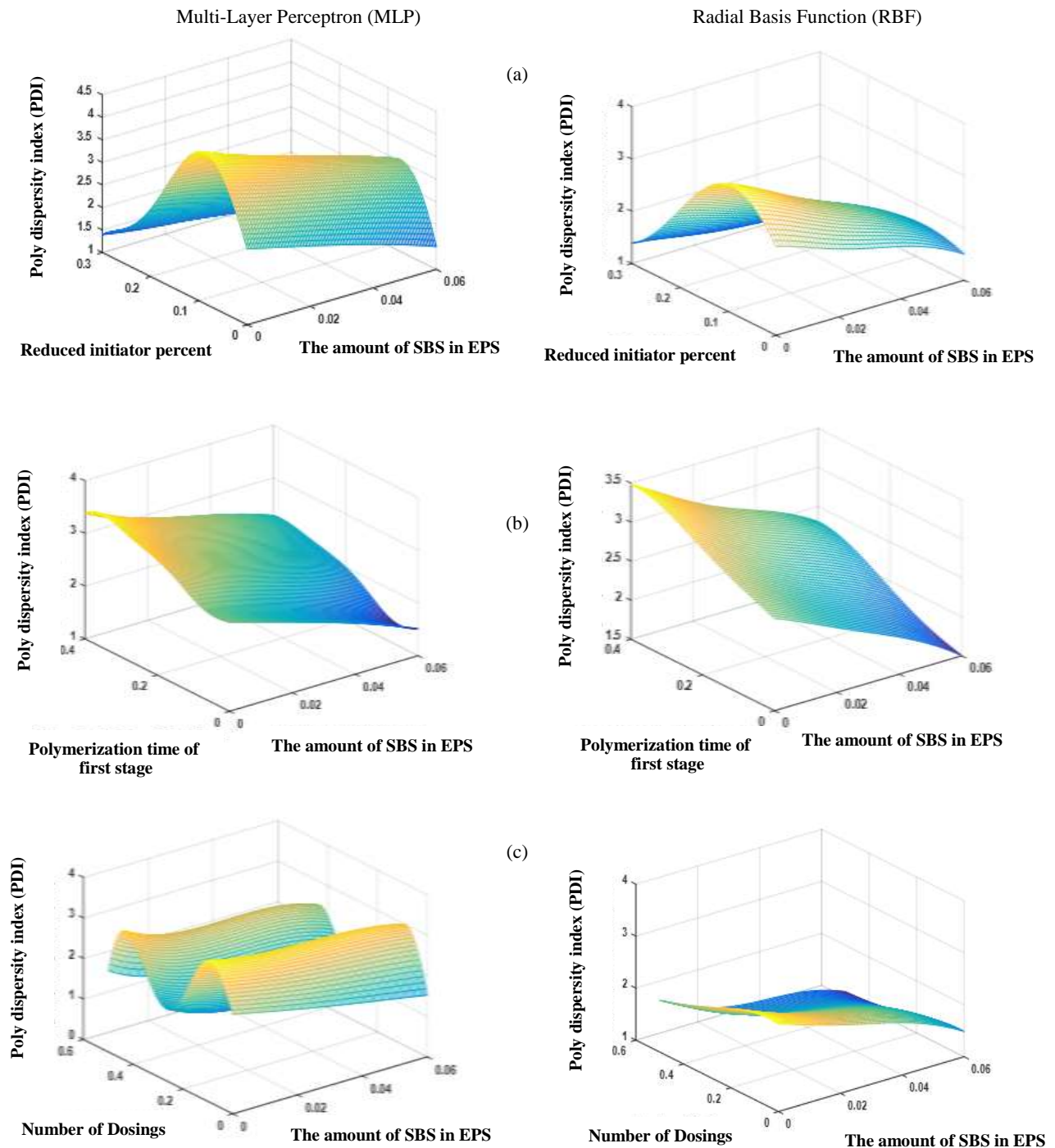

Fig. 16: The results for RBF and MLP methods of ANN for investigating PDI in different states.

Fig. 18-c investigate the number of dosings for both experimental and predicational points and the results of RBF and MLP methods are very close. In Fig. 19 as usual, the results gained from experimental data are as expected and related to studying the amount

of residual monomer for different percentages of SBS in EPS for the states with variable initiators and different times of first-stage polymerization and a number of dosings. For all three states, the MLP method has some noise but in RBF method, the oscillation has not been seen.

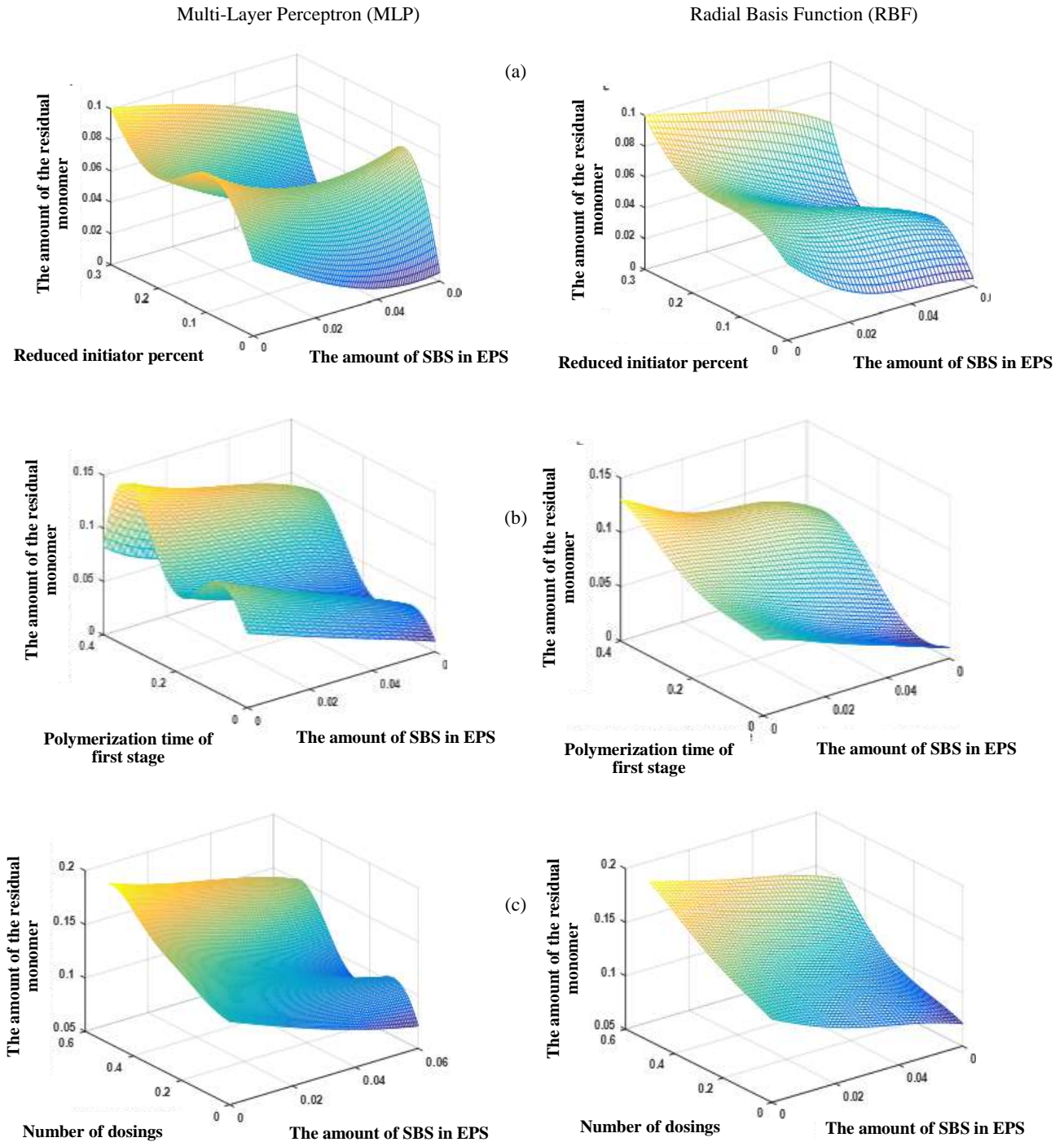

Fig. 17: The results for RBF and MLP methods of ANN for investigating the amount of residual monomer in different states.

But all figures in Fig. 19 show a good match for experimental data with simulation.

## CONCLUSIONS

The result of this study is listed below:

1) With the increase in the percentage of SBS in EPS, the amount of PDI, the percentage of absorbed pentane, and the amount of the residual monomer decrease while the tension in the yield point increases.

2) In constant percentage of SBS, with a decrease

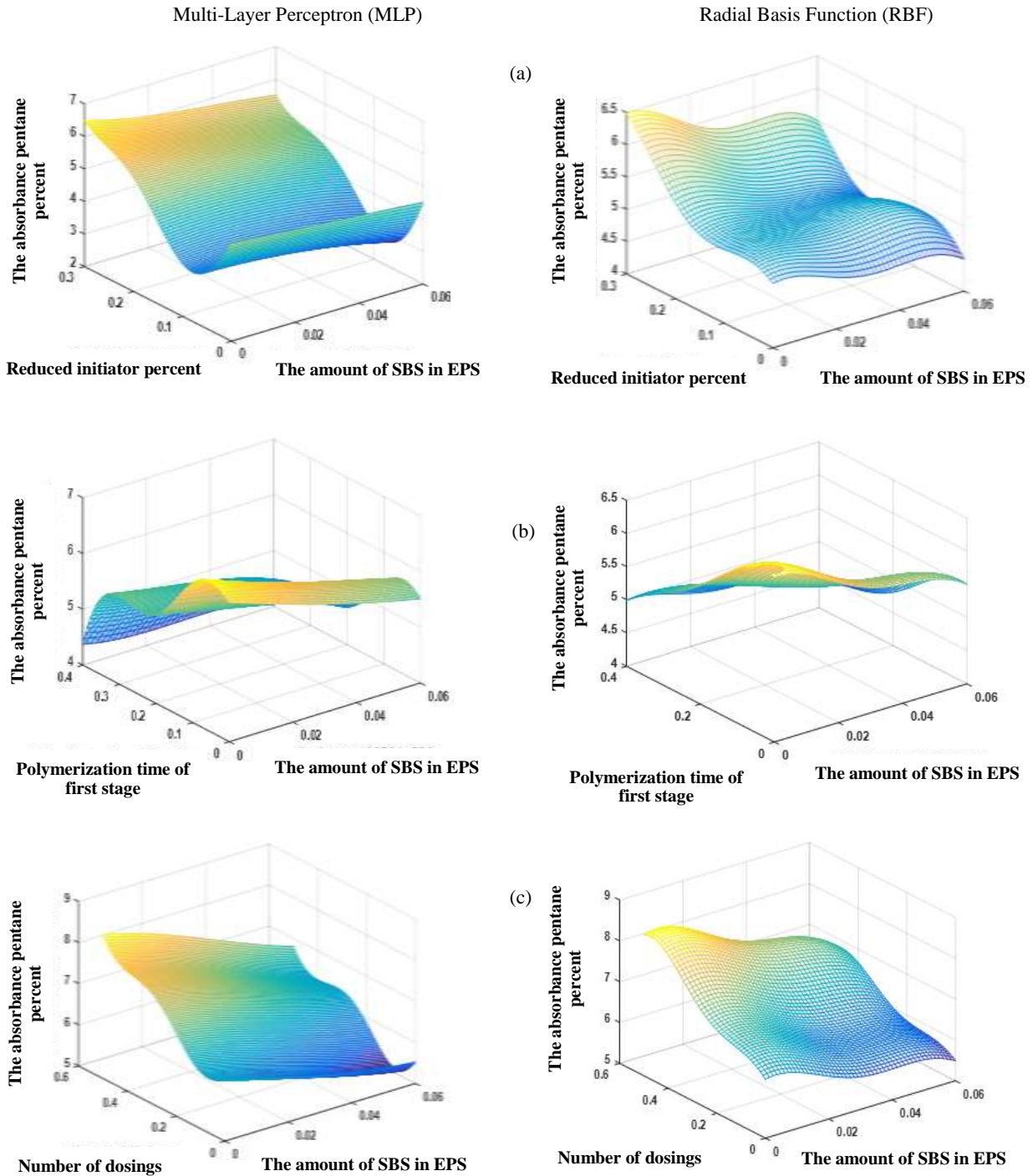

**Fig. 18:** The results for RBF and MLP methods of ANN for absorbed pentane percentage in different states.

in initiator amount and number of dosings and increase in time of the first stage of polymerization, PDI decreases.

3) In a constant percentage of SBS, with a decrease in initiator amount and number of dosings and increase At the time of polymerization, the absorption of pentane increases.

4) Decreasing the amount of initiator and increasing the time of the first stage polymerization and many dosings in constant percentages of SBS in EPS causes an increment in the tension in the yield point.

5) Increasing the amount of the initiator and the time

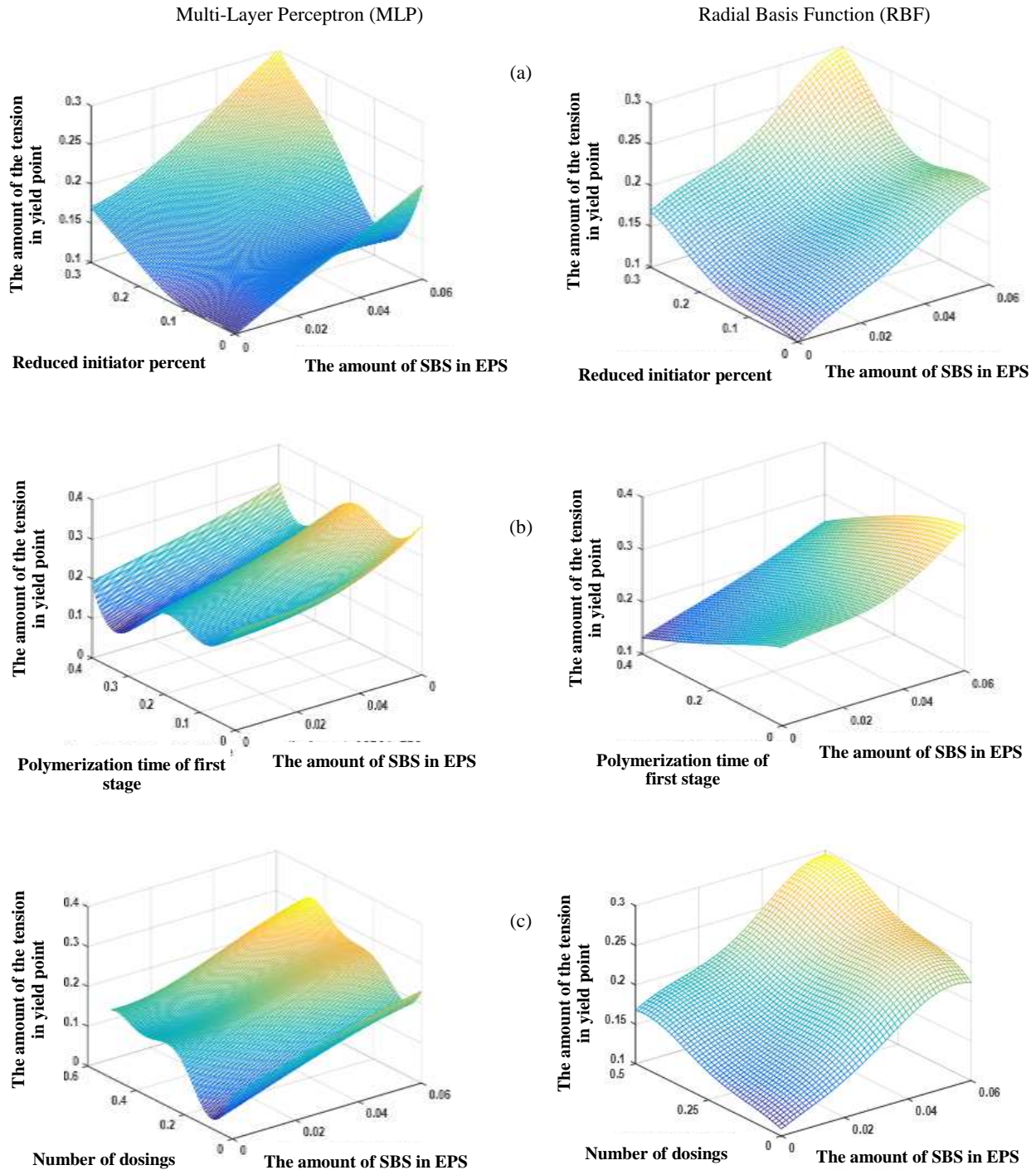

Fig. 19: The results for RBF and MLP methods of ANN for the tension in yield point in different states.

of the first stage polymerization and the number of dosings in the constant percentage of SBS in EPS causes a reduction in the amount of the monomer.

6) Radial Basis Function (RBF) and Multi-Layer Perceptron (MLP) methods of Artificial Neural Networks (ANN)

have simulated the laboratory data perfectly. The MLP method had some noise in some states but the RBF method has better performance due to filtering noises and can be used to predict data for the points which have not been experimented with.

Received : Apr. 19, 2021 ; Accepted : Jul. 19, 2021

## REFERENCES

- [1] Jing X., Peng X.F., Mi H.Y., Wang Y.S., Zhang S., Chen B.Y., Zhou H.M., Mou W.J., **Cell Evolution and Compressive Properties of Styrene-Butadiene-Styrene Toughened and Calcium Carbonate Reinforced Polystyrene Extrusion Foams with Supercritical Carbon Dioxide**, *J. Appl. Polym. Sci.*, **133(23)** (2016). DOI: 10.1002/APP.43508.
- [2] Varnagir S., Tuckute S., Lelis M. Milcius D., **SiO<sub>2</sub> Films as Heat Resistant Layers for Protection of Expandable Polystyrene Foam from Flame Torch-Induced Heat**, *Journal of Thermoplastic Composite Materials*, **31(5)** (2017). DOI: 10.1177/0892705717718238
- [3] Zhang S., Ji W., Han Y., Gu X., Li H., Sun J., **Flame-Retardant Expandable Polystyrene Foams Coated with Ethanediolmodified Melamine-Formaldehyde Resin and Microencapsulated Ammonium Polyphosphate**, *Journal of Applied Polymer Science*, **135(28)**: 46471 (2018). DOI: 10.1002/app.46471
- [4] Sankar L.P., Sivasankar S., Shunmugasundaram M., Kumar A.P., **Predicting the Polymer Modified Ferrocement Ultimate Flexural Strength Using Artificial Neural Network and Adaptive Network Based Fuzzy Inference System**, *Materials Today: Proceedings*, **27**: 1375-1380 (2020). DOI: <https://doi.org/10.1016/j.matpr.2020.02.760>
- [5] Sharma A., Kumar S. A., Kushvaha V., **Effect of Aspect Ratio on Dynamic Fracture Toughness of Particulate Polymer Composite Using Artificial Neural Network**, *Engineering Fracture Mechanics* **228**: 106907, Elsevier, (2020). DOI: <https://doi.org/10.1016/j.engfracmech.2020.106907>,
- [6] Ji W., Yao Y., Guo J., Fei B., Gu X., Li H., Sun J., Zhang S., **Toward an Understanding of How Red Phosphorus and Expandable Graphite Enhance the Fire Resistance of Expandable Polystyrene Foams**, *Journal of Applied Polymer Science*, **137(35)**: 49045 (2020). DOI: 10.1002/app.49045
- [7] Shao X., Du Y., Zheng X., Wang J., Wang Y., Zhao S., Xin Z., Li L., **Reduced Fire Hazards of Expandable Polystyrene Building Materials via Intumescent Flame-Retardant Coatings**, *J Mater. Sci.*, **55**: 7555-7572 (2020). DOI: 10.1007/s10853-020-04548-z
- [8] Nawghare S.M., Mandal J.M., **Effectiveness of Expanded Polystyrene (EPS) Beads Size on Fly Ash Properties**, *International Journal of Geosynthetics and Ground Engineering*, **6**: (2020). DOI: 10.1007/s40891-020-0189-3
- [9] Ji W., Wang D., Guo J., Fei B., Gu X., Li H., Sun J., Zhang S., **The Preparation of Starch Derivatives Reacted with Urea-Phosphoric Acid and Effects on Fire Performance of Expandable Polystyrene Foams**, *Carbohydrate Polymers*, **233**: 115841 (2020). DOI: 10.1016/j.carbpol.2020.115841
- [10] Wang L., Wang C., Liu P., Jing Z., Ge X., Jiang Y., **The Flame Resistance Properties of Expandable Polystyrene Foams Coated with a Cheap and Effective Barrier Layer**, *Construction and Building Materials*, **176**: 403-414 (2018). DOI: <https://doi.org/10.1016/j.conbuildmat.2018.05.023>
- [11] Kannan P., Biernacki J.J., Visco Jr D.P., Lambert W., **Kinetics of Thermal Decomposition of Expandable Polystyrene in Different Gaseous Environments**, *J. Anal. Appl. Pyrolysis*, **84**: 139-144 (2009). DOI: 10.1016/j.jaap.2009.01.003
- [12] Scheirs J., Priddy D., **Modern Styrenic Polymers**. Wiley Series in polymer science, England- Swieten APV, Westmijze H, Schut J (2003) *U.S. Pat. 6639037 (B2)*, (2003).
- [13] Derakhshanfard F., Fazeli N., Vaziri A., Heydarinasab A., **Kinetic Study of the Synthesis of Expandable Polystyrene via Multi-Stage Initiator Dosing Method**, *J. Polym. Res.*, **22**: (2015). DOI: 10.1007/s10965-015-0766-7
- [14] Shan L., Qi X., Duan X., Liu S., Chen G., **Effect of Styrene-Butadiene-Styrene (SBS) on the Rheological Behavior Of Asphalt Binders**, *Construction and Building Materials*, **231**: 117076 (2020). <https://doi.org/10.1016/j.conbuildmat.2019.117076>
- [15] Qian C., Fan W., Yang G., Han L., Xing B., Lv X., **Influence of Crumb Rubber Particle Size and SBS Structure on Properties of CR/SBS Composite Modified Asphalt**, *Construction and Building Materials*, **235**: 117517 (2020). <https://doi.org/10.1016/j.conbuildmat.2019.117517>
- [16] Ghanoun S.A., Tanzadeh J., Mirsepahi M., **Laboratory Evaluation of the Composition of Nano-Clay, Nano-Lime And SBS Modifiers on Rutting Resistance of Asphalt Binder**, *Construction and Building Materials*, **238**: 117592 (2020). <https://doi.org/10.1016/j.conbuildmat.2019.117592>

- [17] Zhang H., Wang H., Zhong W., A Novel Type of Shape Memory Polymer Blend and the Shape Memory Mechanism, *Polymer*, **50(6)**:1596–1601 (2009).  
DOI: 10.1016/j.polymer
- [18] Ben Abdallah A., Kallel A., “Gamaoun F (2017) Shape Memory Property and Driving Force of the Shape Memory Blend (40% PCL/60% SBS)”, *7th International Conference Design Modelling Mechanical System*, Tunisia (2017).  
<https://doi.org/10.1007/s10924-019-01522-y>
- [19] Wang X., Meng S., Tebyetekerwa M., Li Y., Pionteck J., Sun B., Qin Z., Zhu M., Highly Sensitive and Stretchable Piezoresistive Strain Sensor Based on Conductive Poly(Styrene-Butadiene-Styrene)/Few-Layer Graphene Composite Fiber, *Composites: Part A*, **105**: 291–299 (2018).  
<https://doi.org/10.1016/j.compositesa.2017.11.027>
- [20] Yimit M., Ni L., Du Y., Bkan R., Mechanical and Aging Properties of Polypropylene and Styrene-Butadiene-Styrene Composites Under Outdoor and Indoor Conditions, *Strength of Materials*, **50**: 788–799 (2018).  
DOI: 10.1007/s11223-018-0024-4, (2018).
- [21] Hasan M.D.A., Ahmad M., Mannan U.A., Tarefder R.A., Laboratory Investigation and Modeling of High Temperature Performance of Polymer Modified Binders (PMBs) with Different Concentration of Styrene-Butadiene-Styrene (SBS) Polymer, *Airfield and Highway Pavements* (2019).  
DOI: <https://doi.org/10.1061/9780784482469.025>,
- [22] Duong H.C., Chuai D., Woo Y.C., Shon H.K., Nghiem L.D., Sencadas V., A Novel Electrospun, Hydrophobic, and Elastomeric Styrene-Butadiene-Styrene Membrane for Membrane Distillation Applications, *Journal of Membrane Science*, **549(1)**: 420-427 (2018).  
DOI: <https://doi.org/10.1016/j.memsci.2017.12.024>
- [23] Gonzalez-Fernandez I., Iglesias-Otero M.A., Esteki M., Moldes O.A., Mejuto J.C., Simal-Gandara J., A Critical Review on the Use of Artificial Neural Networks in Olive Oil Production, Characterization and Authentication, *Critical Reviews in Food Science and Nutrition*, **59(12)**: 1913-1926 (2018).  
DOI: 10.1080/10408398.2018.1433628
- [24] Swiercz M., Mariak Z., Krejza J., Lewko J., Szydlik P., Intracranial Pressure Processing with Artificial Neural Networks: Prediction of ICP Trends, *Acta Neurochir (Wien)* **142**: 401–406(2000).  
<https://doi.org/10.1007/s007010050449>, (2000).
- [25] Al-Dousari M.M., Garrouch A.A., An Artificial Neural Network Model for Predicting the Recovery Performance of Surfactant Polymer Floods, *Journal of Petroleum Science and Engineering* 109 51–62 (2013).  
<http://dx.doi.org/10.1016/j.petrol.2013.08.012>
- [26] Cecchetti M., Corani G., Guarisoa G., Artificial Neural Networks Prediction of PM10 in the Milan Area. *International Congress on Environmental Modelling and Software*. 140 (2004).
- [27] Xie H., Ma F., “Prediction of Indoor Air Quality Using Artificial Neural Networks”, *Fifth International Conference on Natural Computation*, (2009).  
10.1109/ICNC.2009.502
- [28] Rem B.R., Kaming N.K., Tamowski M., Asteria L., Flaschner N., Becker C., Sengstock K., Weitenberg C., Identifying Quantum Phase Transitions Using Artificial Neural Networks on Experimental Data, *Nature Physics*, (2019).  
<https://doi.org/10.1038/s41567-019-0554-0>
- [29] Derakhshanfard F., Mehralizadeh A., Application of Artificial Neural Networks for Viscosity of Crude Oil-Based Nanofluids Containing Oxides Nanoparticles, *Journal of Petroleum Science and Engineering*, **168**: 263-272 (2018).  
<https://doi.org/10.1016/j.petrol.2018.05.018>
- [30] Hedayati Moghaddam A., Sargolzaei J., Haghghi Asl M., Derakhshanfard F., Effect of Different Parameters on WEPS Production and Thermal Behavior Prediction Using Artificial Neural Network (ANN), *Polymer-Plastics Technology and Engineering*, **51**: 480–486 (2012).  
10.1080/03602559.2011.651243
- [31] Derakhshanfard F., Mehralizadeh A., “Characterization of Polyethylene Terephthalate Wastes/Acrylonitril-Butadiene Styrene (PETW/ABS) Composites with Applications of Artificial Neural Networks”, Springer Nature, Switzerland AG, (2020).  
<https://doi.org/10.1007/s42452-020-03546-9>
- [32] Derakhshanfard F., Mehralizadeh A., Application of Artificial Neural Networks for Viscosity of Crude Oil-Based Nanofluids Containing Oxides Nanoparticles, *Journal of Petroleum Science and Engineering*, (2018).  
DOI: 10.1016/j.petrol.2018.05.018

- [33] Kamari E., Hajizadeh A. A., Kamali M. R., Experimental Investigation and Estimation of Light Hydrocarbons Gas-Liquid Equilibrium Ratio in Gas Condensate Reservoirs through Artificial Neural Networks, *Iranian Journal of Chemistry and Chemical Engineering (IJCCE)*, **39(6)**: 163-172 (2020)  
DOI: 10.30492/ijcce.2019.36496,(2020)
- [34] Akbarzade K., Danaee I., Nyquist Plots Prediction Using Neural Networks in Corrosion Inhibition of Steel by Schiff Base, *Iranian Journal of Chemistry and Chemical Engineering (IJCCE)*, **37(3)**: 135-143 (2018).  
DOI: 10.30492/ijcce.2018.29963 (2018).
- [35] Tarjomannejad A., Prediction of the Liquid Vapor Pressure Using the Artificial Neural Network-Group Contribution Method, *Iranian Journal of Chemistry and Chemical Engineering (IJCCE)*, **34(4)**: 97-137 (2015).  
DOI: 10.30492/ijcce.2015.15461 (2015).
- [36] Ghaemi A., Jafari Z., Etemad E., Prediction of CO<sub>2</sub> Mass Transfer Flux in Aqueous Amine Solutions Using Artificial Neural Networks *Iranian Journal of Chemistry and Chemical Engineering (IJCCE)*, **39(4)**: 269-280 (2020).  
DOI: 10.30492/ijcce.2018.31858 (2020)
- [37] Derakhshanfard F., Mehralizadeh A. Ghazi Tabtabaei Z., Applications of Multi-Layer Perceptron Artificial Neural Networks for Polymerization of Expandable Polystyrene by Multi-Stage Dosing Initiator, *Iranian Journal of Chemistry and Chemical Engineering (IJCCE)*, **41(3)**: 890-901 (2022).  
DOI:10.30492/ijcce.2021.125618.4106,(2021)
- [38] Derakhshanfard F., Vaziri A., Fzeli N., Heydarinasab A., Optimization of Synthesis of Expandable Polystyrene by Multi-Stage Initiator Dosing, *Iranian Journal of Chemical Engineering (IJChE)*, **13(1)**: 20-31 (2016).