

Thermal-Hydraulic Analysis of Heat Pipe Heat Exchanger in a Nuclear Power Plant Using CFD Method

Khorrani Arani, Reza^{*}; Salehi Barough, Mehdi^{}; Poursalehi, Navid[•]**

Nuclear Engineering Department, Central Tehran Branch, Islamic Azad University, Tehran, I.R. IRAN

Jahanfarnia, Gholamreza

Nuclear Engineering Department, Science and Research Branch, Islamic Azad University, Tehran, I.R. IRAN

Zarifi, Ehsan

Reactor and Nuclear Safety Research School, Nuclear Science and Technology Research Institute, Tehran, I.R. IRAN

ABSTRACT: *Using heat pipe cooled micro-reactors in power plants is one of the newest technologies in small power plants. In these power plants, heat is taken from the reactor by several heat pipes and transferred to the working fluid in the main heat exchanger of the power plant. The purpose of this study is the design and thermal-hydraulic analysis of heat pipes and the main heat exchanger of the power plant. The reactor thermal power is 5 MW and its heat is transferred to carbon dioxide as the working fluid in the heat exchanger by 192 potassium heat pipes. The computational fluid dynamics (CFD) method is used for thermal-hydraulic analysis. ANSYS-CFX code, which is a high-performance and reliable tool, is also used for simulation. The results show that the maximum temperature of potassium vapor inside the hottest heat pipe is 913.6 °C. Also, the minimum temperature of the liquid inside the wick structure of this heat pipe is 910.01 °C. Also, the average temperature and pressure of carbon dioxide in the outlet section of the heat exchanger are 649.5 °C and 14.13425 MPa under normal operating conditions. In this situation, carbon dioxide is in a supercritical state and it is possible to use it in the power plant gas cycle.*

KEYWORDS: *potassium Heat pipe, Heat Exchanger, CFD, Thermal-Hydraulic Simulation, ANSYS-CFX, Supercritical Carbon Dioxide.*

INTRODUCTION

In recent years, the desire to build power plants with small dimensions and high safety has increased [1]. These power plants are used to supply electric energy to space

stations, small islands and remote and sparsely populated cities. They can also be used to provide electricity in unexpected events with high reliability. In these power

**To whom correspondence should be addressed.*

+ E-mail: me.salehi@iaua.ac.ir

•Other Address: Medical Radiation Research Center Central Tehran Branch, Islamic Azad University, Tehran, I.R. IRAN.

1021-9986/2024/2/932-945

14/8/6.04

plants, whose thermal power is usually several megawatts, the new generation of small-size reactors are used. Heat pipe cooled micro-reactors are a class of small-sized reactors that differ from traditional reactors in many aspects. Among the features of micro-reactors cooled with heat pipes, we can mention simple design, integrated structure, high inherent safety, higher productivity, lower operating cost, increased usage time and easier control, etc. Also, due to their small size, these reactors can be easily transported and quickly installed [2,3]. The structure of these reactors has been greatly simplified by eliminating common flow pipelines, pumps and auxiliary equipment, which has led to a lower cost and smaller volume system. The heat from fission is transferred to the heat pipes through structural materials, and then the heat pipes transfer the heat directly to the energy converter system. In such a situation, if one or more heat pipes are damaged, the heat can be removed through the adjacent heat pipes, without much impact on the system. Consequently, a localized incident will have little impact on system performance [4,5].

A heat pipe is a two-phase heat transfer device with a very high effective thermal conductivity [6-11]. Therefore, it is a suitable candidate for heat transfer from the micro-reactor core to the working fluid inside the main heat exchanger of the power plant [12-16]. The heat pipe heat exchanger is a part of the power plant gas cycle used to generate electricity.

In the design of a power plant, it is necessary to have a reliable thermal-hydraulic model of the reactor and the main heat exchanger [17-19]. In thermal-hydraulic analysis, energy, momentum and mass conservation equations are solved for micro-reactor core geometry, heat pipes, heat exchanger, and other power plant components. Using the computational fluid dynamics (CFD) method is very useful for accurate, correct and intelligent thermal-hydraulic simulations.

Computational fluid dynamics (CFD) has emerged as an important approach in mechanical and chemical engineering. CFD simulation is a well-established methodology often used to replace or supplement experimental and analytical methods to aid the engineering design and analysis of power plant types. CFD uses numerical methods and data algorithms to solve problems. In the CFD method, partial differential equations of fluids are converted into algebraic equations. Finally, using

methods such as the Finite Difference Method (FDM), Finite Element Method (FEM) and finite volume method (FVM) the investigated geometry is divided into smaller zones to solve the system of linear equations by applying boundary conditions for each node. CFD is applied in a wide range of research in several fields including aerodynamics and aerospace, hypersonic, ventilation, turbomachine, weather simulation, engine and combustion analysis [20-23].

As mentioned, the heat pipe heat exchanger is one of the main parts of an advanced nuclear power plant. However, there have been few studies in this regard. In a study, an analysis method was developed based on the conduction model. The method involved obtaining the specific heat conductance of the heat pipe from a thermal performance test for a single heat pipe and using universal correlations for the convective heat transfer coefficients in tube banks. Additionally, a computer program using finite difference equations was developed to calculate the thermal performance of heat pipe heat exchangers. The method of analysis has been experimentally validated and shown to be applicable in engineering applications [24]. In 2017, a flat heat pipe (FHP) heat exchanger designed for waste heat recovery from high temperature steel production was introduced and tested. The study investigated the thermal performance of the FHP and its heat transfer rate. The results indicate that the FHP shows promise as a technology for waste heat recovery in the steel industry, despite facing challenges such as high temperature sources and limited available space on site [25]. In a paper, a numerical simulation of a heat pipe heat exchanger (HPHE) applied in a residual heat removal system (RHRS) with a thermal resistance network is conducted. Using the finite volume method, the effects of three decisive factors on turbulence and heat transfer are examined. The numerical simulation results align well with the experimental data, with a maximum deviation of less than 10%, indicating reliability [26]. In 2020, a Computational Fluid Dynamic Analysis was conducted on a Heat Pipe Heat Exchanger (HPHE) to predict temperature distribution. The analysis utilized ANSYS-ICEM modular/meshing and FLUENT solver. The study involved modeling the HPHE in four different cases, considering variations such as the presence or absence of fillet near the inlet

and outlet sections, as well as the use of different inlet and outlet section sizes, a horizontal plate near the entrance zone, and three different cones with angles of 36.03 degree, 30 degree, and 45 degree [27]. In 2021, Brough et al conducted a study on the development and validation of the TRNSYS type for simulating heat pipe heat exchangers in transient waste heat recovery applications [28]. In 2021, an HPHE was installed to recover waste heat from a ceramic kiln. The investigation included experimental, theoretical, and numerical analysis. The study estimated the thermal performance of the simulated geometry by implementing design parameters as boundary conditions. These parameters included temperatures and flow rates of the primary and secondary flows in the evaporator and condenser. The numerical results showed that it is possible to recover a thermal power of approximately 101 kW in the unit [29]. In 2022, a study was conducted on a heat pipe heat exchanger to recover energy from waste heat by continuously supplying cooling water. The study included experimental and numerical analyses using waste heat at five different temperatures and three different inlet velocities. The observations focused on overall temperature change, heat transfer on both the hot and cold sides, outlet temperature, and effectiveness [30]. Applying a thermosiphon heat pipe heat exchanger to use the exhaust heat of an indirect water bath heater was studied in 2020. This method aimed to increase the production of distilled water needed for this type of heater [31]. In a 2023 study, researchers experimentally analyzed a heat exchanger with a heat pipe containing zinc oxide (ZnO) nanofluid suspended in a water base. The study observed that as the source's temperature increased, the heat transmission through the heat pipe exchanger with ZnO/H₂O nanoparticles improved [32]. In a paper, a heat pipe heat exchanger (HPHE) was installed to recover heat from a solution heat treatment furnace used in the aluminum industry. Both experimental and theoretical investigations were conducted. The HPHE in the plant recovered 97 kW from the furnace's exhaust stream, with 61 kW being transferred to the secondary stream [33]. In a 2022 study aimed at enhancing energy performance at a gas city gate station, a heat pipe heat exchanger was designed and constructed in a laboratory using the ϵ -

NTU method. The findings revealed that the use of heat pipes led to a reduction in natural gas consumption by 510,132 SCM per year and prevented the annual emission of 756 tons of CO₂ from the city gate station [34].

The main reason for this paper is that in previous studies, the geometry of the main heat exchanger was not specifically designed for power plants that include heat pipe micro-reactors. Also, the thermal-hydraulic analysis of the heat pipe heat exchanger has not been presented before in detail. In this work, the computational fluid dynamics (CFD) method is used for thermohydraulic analysis. For this purpose, first, the geometry of 192 heat pipes that take the heat from the core of a 5 MWth micro-reactor is designed. Then the geometry of the heat exchanger is designed and it is coupled with the geometry of the heat pipes. In this way, it is possible to transfer the heat of the micro-reactor core to the working fluid inside the heat exchanger by heat pipes. The design of a heat exchanger with this geometry for any application has not been reported in any research. After meshing the heat pipe heat exchanger geometry, ANSYS-CFX is used for thermal-hydraulic analysis, and the results are presented. One of the innovative cases of this work is that the effect of changing the diameter of heat exchanger tubes on its performance is investigated and reported. Another novelty of this study is that the effect of heat pipe failure on the thermal-hydraulic behavior of the working fluid inside the heat exchanger is investigated. While in previous studies, the effect of heat pipe failure on changes in the structural materials of the micro-reactor core has been investigated.

MATERIAL AND METHOD

The Heat Pipe Geometry Design

As mentioned before, heat pipes are used in the design of the micro-reactor core to take heat from the core and transfer it to the heat exchanger and the fluid circulating inside it. The heat pipe is a closed chamber including wall, end caps, wick structure and working fluid [35] and is shown in Fig. 1. The wick structure is designed in different ways in heat pipes. In 2015, heat pipes with different shapes were designed and analyzed for the Wick structure [20]. In the present study, the length of the evaporator, adiabatic, and condenser sections are considered 100, 70, and 100 cm, respectively. The heat pipe design criteria are given in Table 1.

Table 1: The Heat Pipe Design Criteria

Parameter	Value
Heat Pipe Vapor Core Diameter (cm)	3
Heat Pipe Wick Thickness (cm)	0.1
Heat Pipe Wall Thickness (cm)	0.1
Heat Pipe Vapor Core Length (cm)	270

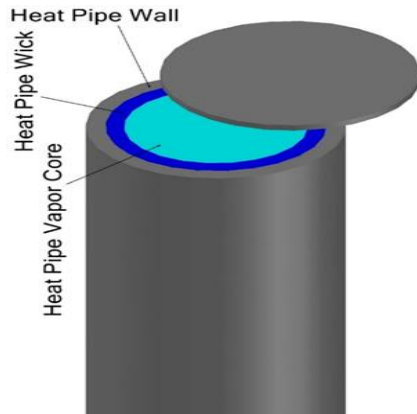

Fig. 1: The Heat Pipe Scheme

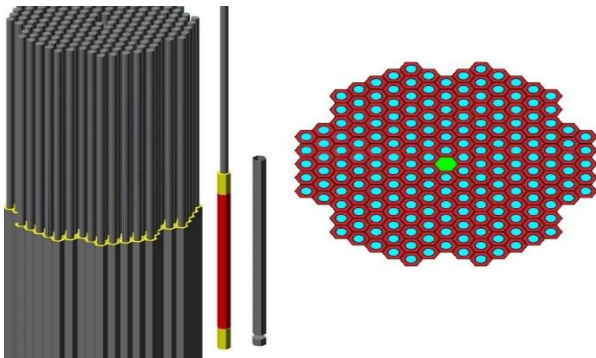

Fig 2: A View of Micro-Reactor Core and Heat Pipes Arrangement

The micro-reactor core contains 192 heat pipes with one-sixth symmetry in the triangular grid (Fig. 2).

The Heat Exchanger Geometry Design

In the condensing area of the heat pipes, a heat exchanger is designed to transfer the heat dissipated from the heat pipes to the working fluid in the next cycle. Figs. 3 and 4 show the designed heat exchanger with twelve inlets at the top and twelve outlets at the bottom for the circulating cooling fluid. The area of each inlet section and each outlet section of the heat exchanger is 0.01452 m². In other words, the total area sections of the fluid inlets to the heat exchanger are 0.17424 m². Also, the total volume of circulating fluid inside the heat exchanger is 0.34361 m³.

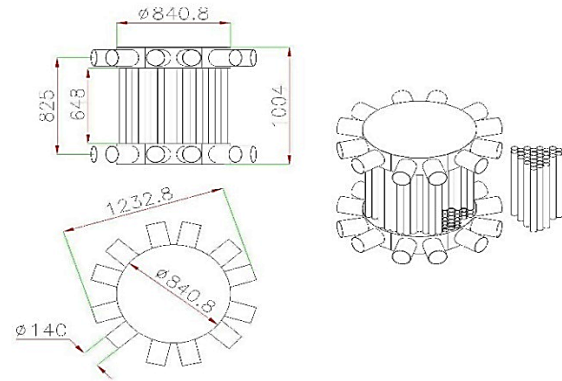

Fig. 3: The Heat Exchanger Design

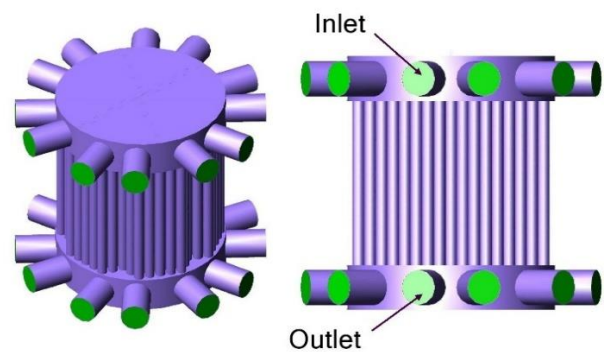

Fig. 4: A View of Main Heat Exchanger in Power Plant

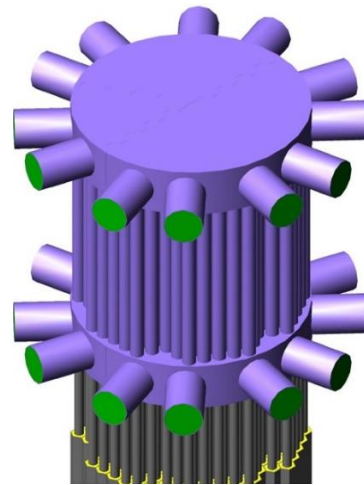

Fig. 5: Coupling of Heat Pipes Geometry and Heat Exchanger Geometry

Coupling of Heat Pipes Geometry and Heat Exchanger Geometry

Next, as shown in Fig. 5, the designed geometry for the micro-reactor core is coupled with the geometry of the heat exchanger. So that each of the heat pipes is placed inside one of the heat exchanger tubes.

Table 2: The Meshing Specifications of the Geometry

Component	Number of nodes	Number of elements	Value of Skewness
Fluid in heat exchanger tubes	1099241	4835449	0.238939
Fluid in a heat pipe	274856	516510	0.12897

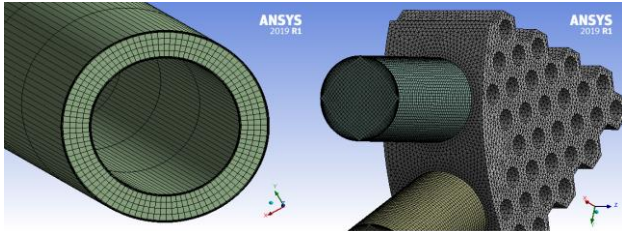
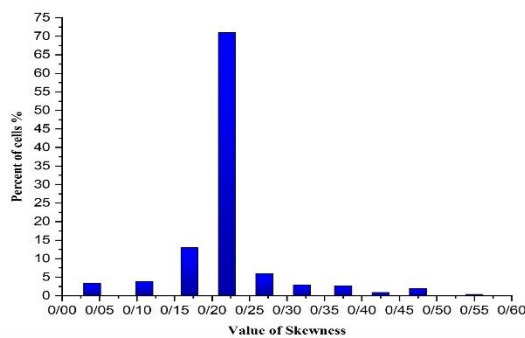
**Fig. 6: Meshing of Fluid Flow Inside Heat Exchanger Tubes and Collectors****Fig. 7: Checking the Mesh Quality for the Fluid Inside the Heat Exchanger Tubes**

Geometry Meshing

Hexagonal mesh is used for heat pipes. Also, two types of tetrahedron and hexagonal meshes have been used for fluid meshing inside heat exchanger collectors. To more accurately determine the extreme velocity gradients in the gas flow and near the wick structures, the boundary layer mesh has been used for heat pipes. In the gas flow meshing in the heat exchanger tubes and collectors, the boundary layer mesh is also used near the walls (Fig. 6).

One of the important criteria in checking the quality of the meshed geometry is the Skewness which is the deviation between the optimal cell size to the existing cell size. The total range of skewness is between 0 (ideal) to 1 (worst), however, the acceptable range is from 0 to 0.25. The skewness for Hexahedral cells is followed by the deviation between the vertex angles of face pairs of a hexahedron and the ideal vertex angle of 90 degrees [36]. Fig. 7 shows the mesh quality investigation for the fluid inside the heat exchanger tubes. The average value of the Skewness criterion for the fluid inside the heat exchanger

tubes was measured at 0.238939. In Table 2, the meshing specifications of the geometry of the fluid inside the heat exchanger tubes and the fluid inside a heat pipe are presented.

The ANSYS-CFX Code

ANSYS-CFX is a high-performance computational fluid dynamics (CFD) software tool that delivers reliable and accurate solutions quickly and robustly across a wide range of CFD and multiphysics applications. CFX is recognized for its outstanding accuracy, robustness and speed in thermal-hydraulic simulation of reactors. At the heart of the CFX is its innovative solver technology which is the main driving force to achieve highly reliable and accurate results in a much more efficient manner as compared to other CFD solvers. The advanced CFX solver allows users to choose many physical models to capture any type of phenomenon associated with fluid flow. The CFX code includes three parts: CFX-Pre, CFX-Solver, and CFX-Post [37-39].

The CFX code uses the Finite Volume Method (FVM) for computational fluid dynamics. This numerical technique transforms partial differential equations representing conservation laws over differential volumes into discrete algebraic equations over finite volumes. The geometric domain is discretized into non-overlapping elements or finite volumes, similar to the finite difference or finite element method. The partial differential equations are then transformed into algebraic equations by integrating them over each discrete element. The system of algebraic equations is then solved to compute the values of the dependent variable for each element. The FVM turns some of the terms in the conservation equation into face fluxes and evaluates them at the finite volume faces. The FVM is strictly conservative because the flux entering a given volume is identical to that leaving the adjacent volume. This makes it the preferred method in CFD. The FVM can be formulated in the physical space on unstructured polygonal meshes. Finally, it is easy to implement a variety of boundary conditions in a noninvasive manner in the FVM. The unknown variables are evaluated at the centroids of the volume elements, not at their boundary

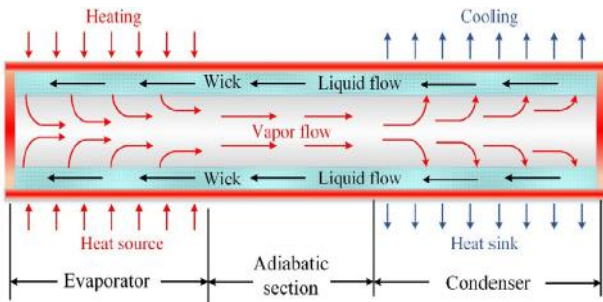

Fig. 8: The Heat Pipe Performance [18]

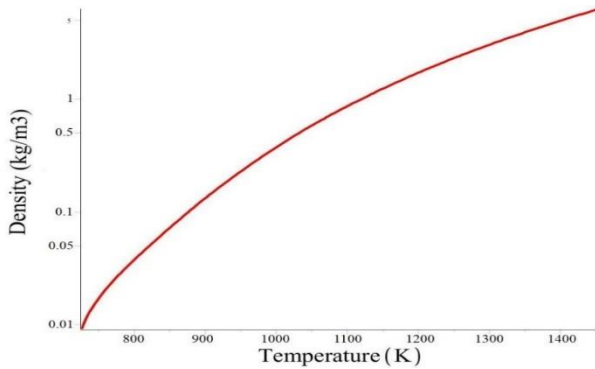

Fig. 9: Changes in the Density of Saturated Vapor of Potassium

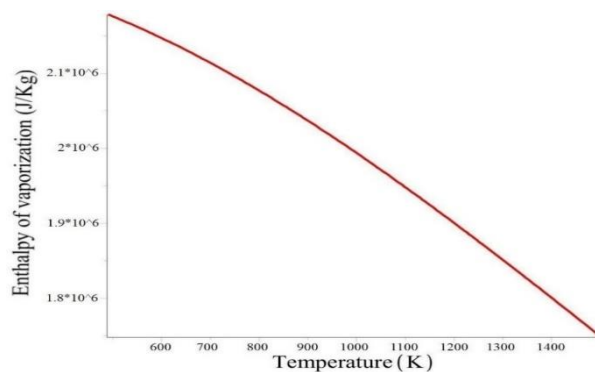

Fig. 10: Changes in Enthalpy of Vaporization of Potassium

faces, making it quite suitable for the numerical simulation of fluid flow, heat, and mass transfer applications. The FVM is now capable of dealing with all kinds of complex physics and applications from its limited potential at inception confined to solving simple physics and geometry over structured grids [40-41].

The Heat Pipe Performance

In recent years, to prevent core damage and increase the safety of nuclear power plants, passive decay heat removal systems such as natural circulations and heat pipe structures have progressed [42, 43]. In the micro-reactor

design, heat pipes are used to take heat from the core and transfer it to the working fluid in the heat exchanger. The heat pipe is a closed chamber including a wick structure and working fluid. A heat pipe is an effective constant-temperature heat transfer device driven by a phase change of working fluid. When the heat reaches the evaporator section, the working fluid evaporates and creates a pressure gradient in the pipe. This pressure gradient causes the vapor to move along the pipe to reach the condenser. In the condenser, the vapor condenses and the final heat of its evaporation is released. Then, the working fluid returns to the evaporator in a liquid state by capillary pressure from inside the wick structure. The wick structure is a porous medium that has been designed and developed in different way [44-56]. Common heat pipes include three sections: the evaporator, the adiabatic, and the condenser (Fig. 8). In this study, the length of the evaporator, adiabatic, and condenser parts are considered 100, 70, and 100 cm, respectively.

In this study, potassium fluid was used inside the heat pipes. For the correct operation of the heat pipes in the micro-reactor core and inside the heat exchanger, the precise definition of the potassium thermophysical properties in CFX is very important. These properties include density, thermal conductivity coefficient, specific heat capacity for saturated vapor and liquid, pressure for saturated vapor and enthalpy of vaporization. Figs. 9 and 10 show graphs of changes in saturated vapor density and enthalpy of vaporization [47]. It is added that recently there have been studies about the possibility of using other fluids including nanofluids due to their special and unique characteristics in heat transfer in heat pipes. Investigating the thermophysical properties of this type of fluid is possible with methods such as molecular dynamics simulation [48-56].

The Main Heat Exchanger Performance

A heat exchanger is a device used to transfer heat between two or more fluids. The fluids can be single or two-phase and, depending on the exchanger type, may be separated or in direct contact. There are different heat exchangers, such as shell and tube and gasket-plate heat exchangers [57-61]. As mentioned before, in this work, the main heat exchanger of the power plant main is placed in the condensing section of the heat pipes. This heat exchanger contains 192 tubes and the heat pipes are placed

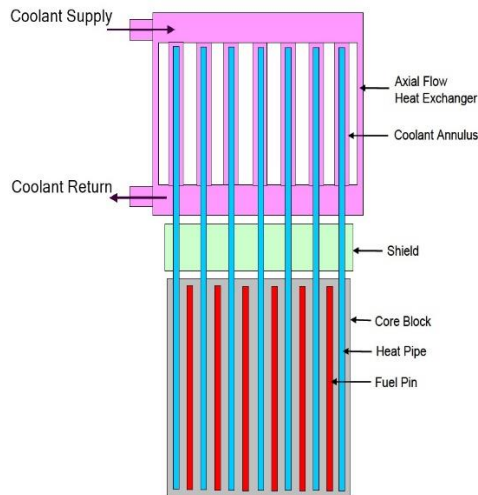

Fig. 11: The Simplified Heat Pipe Heat Exchanger

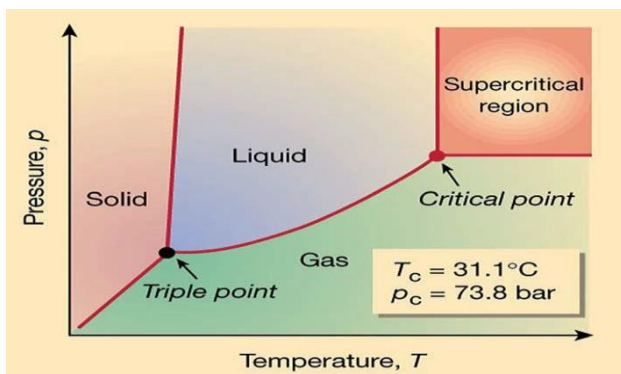

Fig. 12: Pressure-Temperature Phase Diagram of CO₂ [64]

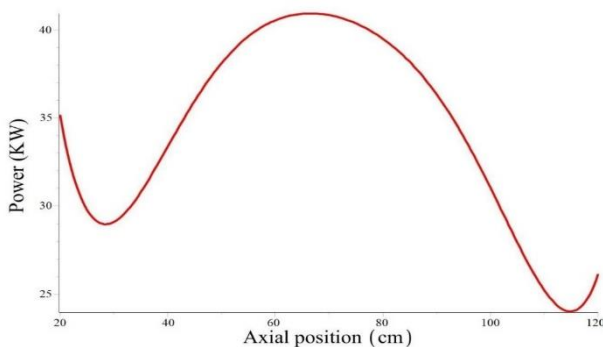

Fig. 13: Variations of the Axial Thermal Power of the Fuel Slug in the Hottest Fuel Element

in them. The working fluid in the heat exchanger tubes is supercritical carbon dioxide, and after receiving heat from the heat pipes, it circulates in the power plant gas cycle. The mass flow rate of carbon dioxide is 35 Kg/s. This heat exchanger has 12 inlet and 12 outlet sections for supercritical carbon dioxide. Using this number of input

and output sections helps to have a better thermal uniformity flow and more redundancy in the power plant. The supercritical carbon dioxide flow enters from the top of the heat exchanger and exits from the bottom. Fig. 11 shows the schematic view.

Carbon dioxide with the chemical formula CO₂ is a compound consisting of two oxygen atoms and one carbon atom. This gas is colorless, odorless, non-flammable and does not have much toxicity in low concentrations. This gas has a strong acidic smell in high concentrations. Carbon dioxide at 78.51 °C changes from solid state to gas state directly (or vice versa). Using this gas as a working fluid in power generation cycles has many advantages, including its relatively low critical pressure. In fact, due to the low critical pressure of carbon dioxide, it is easier to turn it into a liquid than other gases, including helium. Also, the beneficial use of carbon dioxide resulting from the combustion process in power cycles can prevent further release of this gas into the earth's atmosphere. Another important point is that carbon dioxide has suitable critical conditions. In other words, achieving a temperature of 31.1 °C and a pressure of 7.38 MPa is not so difficult (Fig. 12) [62,63].

Considering that the total thermal power of the core is 5 MWth, the average thermal power for each fuel element is about 26 KWth. Fig. 13 illustrates the axial thermal power of the nearest fuel element to the core center [65]. The thermal power of all fuel elements (including heat pipes) was defined in CFX.

RESULTS AND DISCUSSION

Figs 14 to 17 show the axial temperature changes of the components of the hottest heat pipe (including heat pipe wall, liquid inside the wick structure and vapor inside the heat pipe) in three sections: the evaporator, the adiabatic and the condenser. In the evaporator section (height 0 to 100 cm), the liquid receives heat from the fuel slug and turns into vapor. Then this vapor travels through the adiabatic section to the condenser section due to the pressure difference between the evaporator and the condenser. In the evaporator section, the changes in the axial temperature of the heat pipe components follow the changes in the axial thermal power of the fuel slug. In this section, the maximum vapor temperature is observed at a height of 49.54 cm and is equal to 913.3 °C. In the adiabatic section (height 100 to 170 cm), the axial temperature changes of the heat pipe components are very

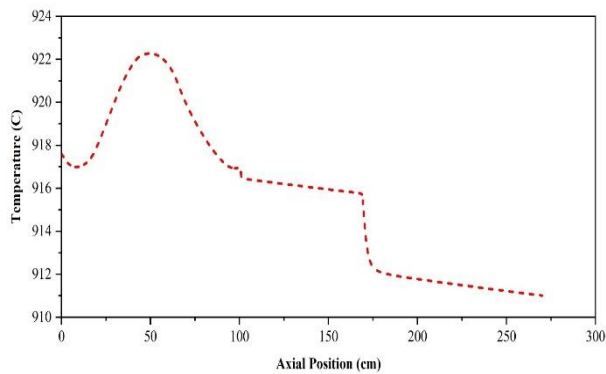

Fig. 14: Axial Temperature Variations of the Heat Pipe Wall in the Hottest Fuel Element

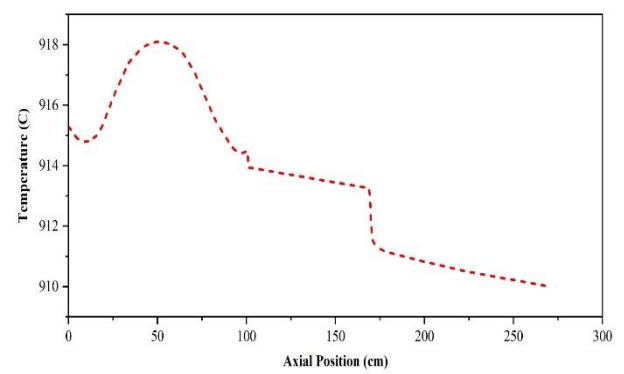

Fig. 16: Axial Temperature Variations of Liquid Inside the Wick Structure in the Hottest Fuel Element

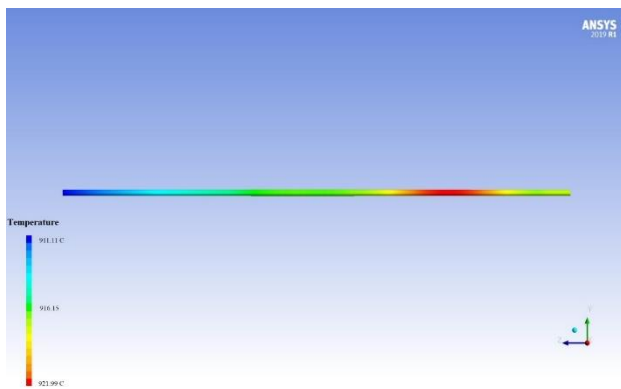

Fig. 15: A View of the Axial Temperature Changes of the Heat Pipe Wall

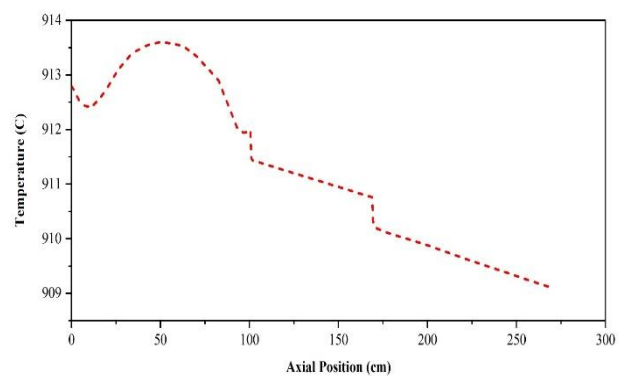

Fig. 17: Axial Temperature Variations of the Vapor Inside the Heat Pipe in the Hottest Fuel Element

low because it is insulated. In the condenser section (height 170 to 270 cm), the vapor releases heat and becomes liquid. The heat released is transferred to the working fluid inside the heat exchanger. In this section, the axial temperature changes of the heat pipe components decrease with the increase of the height parameter. The minimum temperature of the liquid inside the wick structure in this section is 910.01 °C. The results show that the difference between the maximum and minimum temperature of the vapor inside the heat pipe is less than the difference between the maximum and minimum temperature of the liquid inside the wick structure. The difference between the minimum and maximum temperature of the vapor inside the heat pipe is very low and equal to 4.5 °C, which shows that the vapor inside the pipe has an almost constant temperature. Hence, the heat pipe is known as a constant temperature device.

Fig. 18 shows the changes in the average temperature of carbon dioxide inside the heat exchanger in the axial direction. The dissipated heat from the condenser section

of the heat pipes is absorbed by working fluid inside the heat exchanger and its temperature increases. The increase in the temperature of carbon dioxide inside the heat exchanger is 301 so °C that the temperature in the outlet section becomes 649.5°C. In Fig. 19, the temperature changes of the working fluid inside the heat exchanger can be seen in 3D.

Pressure drop is a vital parameter in the design and calculations of heat exchangers, which has a great impact on the efficiency and performance of the process, and knowing its causes provides insight to reduce its harmful effects. Basically, the pressure drop represents a kind of energy loss and this is due to the friction between the fluid molecules themselves or between the molecules and the walls of the fluid flow passages in the heat exchanger. The factors that cause the fluid pressure drop inside the heat exchanger are the diameter and length of the tubes, roughness or friction coefficient of the surfaces, fluid flow velocity and fluid viscosity.

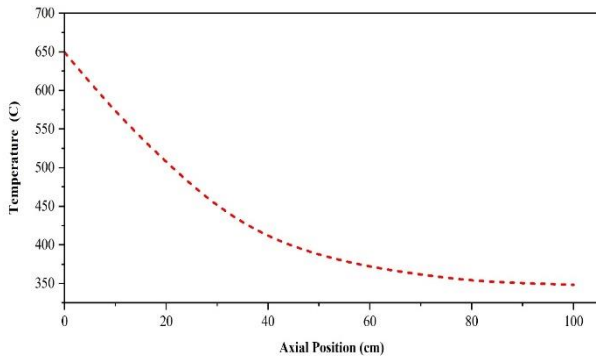

Fig. 18: Changes in Average Temperature of Carbon Dioxide Inside the Heat Exchanger in the Axial Direction (for the Closest Tube to the center)

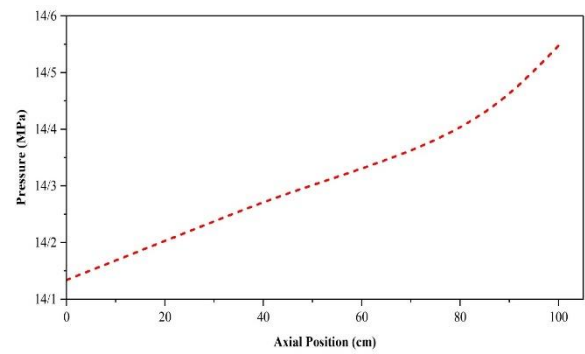

Fig. 20: Changes in Average Pressure of Carbon Dioxide Inside the Heat Exchanger in The Axial Direction (for the Closest Tube to the Center)

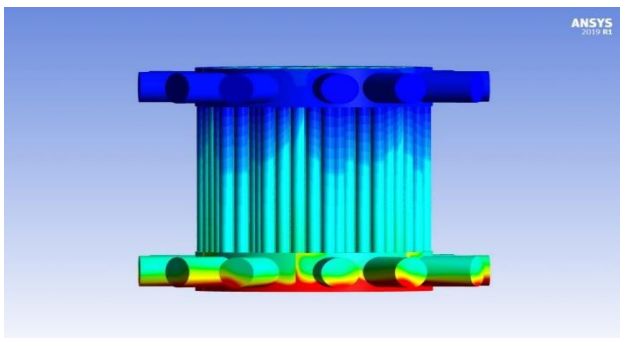

Fig. 19: 3D view of Average Temperature Changes of the Working Fluid Inside the Heat Exchanger

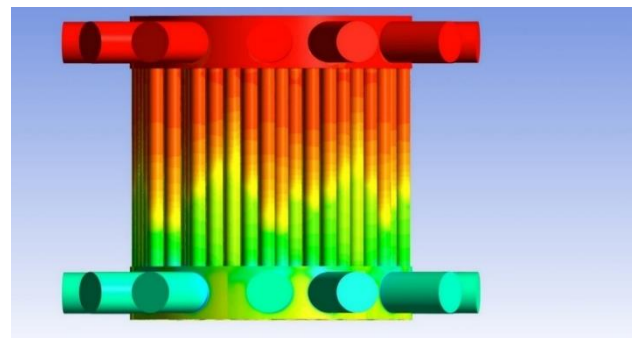

Fig.21: 3D View of Average Pressure Changes of the Working Fluid Inside the Heat Exchanger

In Fig. 20, the changes in the average pressure of carbon dioxide inside the heat exchanger in the axial direction are presented. As can be seen, the working fluid pressure decreases while passing through the heat exchanger tubes. The pressure drop of the working fluid in the heat exchanger is equal to 413.68 KPa so that carbon dioxide pressure in the heat exchanger outlet section is 14.13425 MPa. In Fig. 21, the changes in the pressure of working fluid inside the heat exchanger can be seen in 3D. The diameter of tubes in the heat exchanger design significantly affects the fluid pressure drop [66-69]. When using smaller diameter tubes, there is less space for fluid to move. Therefore, more resistance is created against the fluid flow. This restriction means that the fluid has to work harder to pass through the tubes, resulting in an increased pressure drop. In other words, by reducing the diameter of the tubes and reducing the cross-section of the fluid passage, the velocity of the fluid increases and the friction between the fluid and the wall of the pipes also increases and subsequently leads to a greater pressure drop. An increase in pressure drop leads to a decrease in system

performance. Therefore, more power is needed to compensate for the pressure drop while maintaining the appropriate velocity of the fluid flow, and this can lead to a significant increase in energy consumption.

In this work, to investigate the effect of changing the geometry of the heat exchanger on the fluid pressure drop (Without changing the mass flow rate), the diameter of the heat exchanger tubes was reduced by 1 mm. This was done by increasing the wall thickness of the tubes. According to the results, the pressure drop has increased and is now at 485.69 KPa.

The heat pipes failure is one of the accidents that may happen in a nuclear reactor. Certainly, with several heat pipes failing, the heat transfer of the core to the working fluid inside the heat exchanger is reduced. In a specific scenario, 3 heat pipes with thermal power of 34.3 KWth, 31.3 KWth, and 25.3 KWth failed. In this case, the average temperature of carbon dioxide inside the heat exchanger decreased so that the temperature of the fluid exiting the heat exchanger reached 646.1°C. This temperature shows that carbon dioxide is still in a critical state (Fig.22).

Table 3: Comparison of Results

Parameters of the hottest heat pipe	Present Study (°C)	Idaho National Laboratory (°C)	Percentage change
Max vapor temp in the evaporator	913.6	927.15	1.48
Max vapor temp in the condenser	910.24	926.65	1.80
Max liquid temp in the evaporator	918.1	928.6	1.14
Max liquid temp in the condenser	912	926.35	1.57
Max wall temp in the evaporator	922.3	929.55	0.78
Max wall temp in the condenser	914.63	925.35	1.17
CO ₂ parameters in the heat exchanger	Present Study	Los Alamos National Laboratory	Percentage change
Temperature in the outlet	649.5	652	0.38

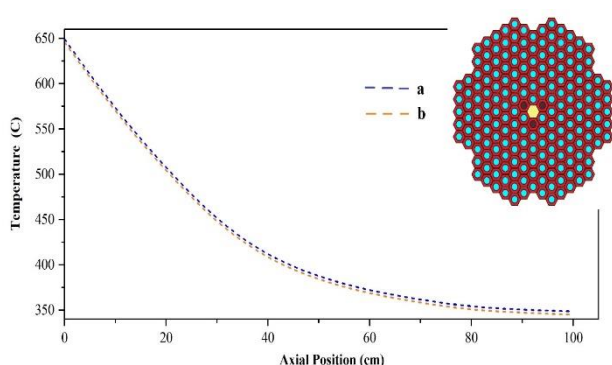

Fig. 22: Average Temperature Changes in CO₂ Inside Heat Exchanger in the Axial Direction for Normal Operation (a) and Accident Scenario (b)

As mentioned earlier, few studies have been done on heat pipe heat exchangers and especially their thermal-hydraulic analysis in a power plant equipped with a 5 MWth micro-reactor, and not many results are available. Therefore, there are limitations for comparison. However, research has been done in the Idaho National Laboratory [70] regarding the analysis of potassium heat pipes and in the Los Alamos National Laboratory [3] regarding the analysis of carbon dioxide as a circulating fluid inside the heat exchanger of a 5 MWth power plant using the development of nuclear codes and the summary of their results and comparison with the results of the present research is reported in Table 3. This comparison indicates the results obtained in the present study have minimal differences from previous studies and are valid.

CONCLUSION

According to some benefits including a compact design, more safety, improved system reliability and

stability, and easy transportation, the interest in the design, construction, and development of power plants equipped with heat pipe cooled micro-reactors as innovative and new-generation models have increased significantly in recent years. In these power plants, the heat produced in the reactor is transferred to the working fluid inside the main heat exchanger by several heat pipes. Heat pipes are characterized by their ability to transfer large amounts of heat quickly even between a relatively small temperature difference, not requiring a power source, and having a long operational life. In this paper, the main heat exchanger of the power plant, which receives heat through 192 potassium heat pipes from a 5 MW micro-reactor, was designed and analyzed. The working fluid circulating inside the heat exchanger is supercritical carbon dioxide. The CFD method and CFX code were used in the thermohydraulic analysis of the heat pipe heat exchanger. The results showed that in the evaporator part, the axial temperature changes of the heat pipe components (including heat pipe wall, liquid inside the wick structure and vapor inside the heat pipe) follow the axial thermal power changes of the fuel slug. The maximum temperature of the wall, vapor and liquid inside the wick structure in the evaporator section of the hottest heat pipe was calculated as 922.3 °C, 918.1 °C and 913.6 °C, respectively. Also, the average temperature and pressure of carbon dioxide in the outlet section of the heat exchanger were 649.5 °C and 14.13425 MPa, respectively. Achieving this temperature and pressure causes carbon dioxide to be in a supercritical state. Investigating the effect of the change in the geometry of the heat exchanger tubes revealed that by reducing the diameter of the tubes to 1 mm, the pressure drop increased to 485.69 KPa. Due to the

inherent reliability and safety of these power plants, in the event of an accident due to the failure of three of the hottest heat pipes, the average temperature of carbon dioxide in the outlet section of the heat exchanger will decrease very slightly and reach 646.1 °C. In the future, there will be a possibility of thermodynamic analysis of the gas cycle of power plants that include micro-reactors and heat pipe heat exchangers. It is also possible to study the effect of changing the working fluid in the heat pipes and heat exchanger on the performance of the power plant.

Received : Nov.23, 2023 ; Accepted : Jan.15, 2024

REFERENCES

- [1] Zohuri B., *Nuclear Micro Reactors*, Springer, (2020).
- [2] Zhang W., Zhang D., Wang C., Tian W., Qiu S., Su G., *Conceptual Design and Analysis of a Megawatt Power Level Heat Pipe*, *Annals of Nuclear Energy*, **144(1)**:107576 (2020).
- [3] McClure P., Poston D., Rao D.V., Reid R., *Design of Megawatt Power Level Heat Pipe Reactors*, *Los Alamos National Laboratory*, LA-UR-15-28840 (2015).
- [4] Ma Y., Chen E., Yu H., Zhong R., Deng J., Chai X., Huang S., Ding S., Zhang Z., *Heat Pipe Failure Accident Analysis in Megawatt Heat Pipe Cooled Reactor*, *Annals of Nuclear Energy*, **149**: 107755 (2020).
- [5] Ma, Y., Tian, C., Yu, H., Zhong, R., Zhang, Z., Huang, S., Deng J., Chai X., Yang, Y., *Transient Heat Pipe Failure Accident Analysis of a Megawatt Heat Pipe Cooled Reactor*, *Progress in Nuclear Energy*, **140**: 103904 (2021).
- [6] Jose J., Hotta T.K., *A Comprehensive Review of Heat Pipe: Its Types, Incorporation Techniques, Methods of Analysis and Applications*, *Thermal Science and Engineering Progress*, **42**: 101860 (2023).
- [7] Pagliarini L., Iwata N., Bozzoli F., *Pulsating Heat Pipes: Critical Review on different Experimental Techniques*, *Experimental Thermal and Fluid Science*, **148**: 110980 (2023).
- [8] Kargarsharifabad H., Jahangiri Mamouri S., Shafii M.B., Taeibi Rahni M., *Experimental Investigation of the Effect of using Closed-Loop Pulsating Heat Pipe on the Performance of a Flat Plate Solar Collector*, *Journal of Renewable Sustainable Energy*, **5(1)**: 013106 (2013).
- [9] Jalilian M., Kargarsharifabad H., Abbasi Godarzi A., Ghofrani A., Shafii M.B., *Simulation and Optimization of Pulsating Heat Pipe Flat-Plate Solar Collectors Using Neural Networks and Genetic Algorithm: A Semi-Experimental Investigation*, *Clean Technologies and Environmental Policy*, **18**: 2251–2264 (2016).
- [10] Rastegar S., Kargarsharifabad H., Shafii M.B., Rahbar N., *Experimental Investigation of the Increasing Thermal Efficiency of an Indirect Water Bath Heater by Use of Thermosyphon Heat Pipe*, *Thermal Science*, **24(6)**: 4277-4287 (2020).
- [11] Shoeibi S., Kargarsharifabad H., Rahbar N., Khosravi G., Sharifpur M., *An Integrated Solar Desalination with Evacuated Tube Heat Pipe Solar Collector and New Wind Ventilator External Condenser*, *Sustainable Energy Technologies and Assessments*, **50**: 101857 (2022).
- [12] Cao H., Wang G., *The Research on the Heat Transfer of a Solid-Core Nuclear Reactor Cooled*, *Annals of Nuclear Energy*, **130**: 431–439 (2019).
- [13] Mueller C., Tsvetkov P., *Novel Design Integration for Advanced Nuclear Heat-Pipe Systems*, *Annals of Nuclear Energy*, **141**: 107324 (2020).
- [14] Shi S., Liu Y., Yilgor I., Sabharwall P., *A two-Phase Three-Field Modeling Framework for Heat Pipe Application in Nuclear Reactors*, *Annals of Nuclear Energy*, **165**: 108770 (2022).
- [15] Zhang X., Sun H., Huang J., Sun, P., Wei, X., *Control Strategy Study for a Heat Pipe Cooled Nuclear Reactor*, *Annals of Nuclear Energy*, **190**: 109849 (2023).
- [16] Li S.N., Liang Z.T., Yan, B.H., *A Medium Temperature Heat Pipe Cooled Reactor*, *Annals of Nuclear Energy*, **172**: 109068 (2022).
- [17] Schriener T.M., El-Genk M. S., *Thermal-Hydraulics and Safety Analyses of the Solid Core-Sector Compact Reactor (SC-SCoRe) and Power System*, *Progress in Nuclear Energy*, **76**: 216–231 (2014).
- [18] Liu X., Zhang R., Liang Y., Tang S., Wang C., Tian W., Su G., Zhang Z., Qiu S., *Core Thermal-Hydraulic Evaluation of a Heat Pipe Cooled Nuclear Reactor*, *Annals of Nuclear Energy*, **142**: 107412 (2020).
- [19] Wang C., Sun H., Tang S., Tian W., Qiu S., Su G., *Thermal-Hydraulic Analysis of a New Conceptual Heat Pipe Cooled*, *Nuclear Engineering and Technology*, **52(1)**: 19-26 (2020).

- [20] Naveenkumar C., Kumar P., Kumar K., [Simulation and CFD Analysis of Heat Pipe with Different Wick Geometry using CFX](#), *International Journal of Thermal Technologies*, **5**: No.3. (2015).
- [21] Höhne T., [CFD Simulation of a Heat Pipe Using the homogeneous Model](#), *International Journal of Thermofluids*, **15**: 100163 (2022).
- [22] Sun H., Pellegrini M., Wang C., Suzuki S., Okamoto K., Tian W. Qiu S., Su G., [CFD Simulation Based on Film Model of High Temperature Potassium Heat Pipe at different Positions: Horizontal, Vertical, and 45° Inclined](#), *Progress in Nuclear Energy*, **154**: 104442 (2022).
- [23] Wang K., Hu C., Cai Y., Li Y., Tang D., [Investigation of Heat Transfer and Flow Characteristics in Two-Phase Loop Thermosyphon by Visualization Experiments and CFD Simulations](#), *International Journal of Heat and Mass Transfer*, **203**: 123812 (2023).
- [24] Huang B., Tsuei J., [A Method of Analysis for Heat Pipe Heat Exchangers](#), *International Journal of Heat Mass Transfer*, **28(3)**: 553-562 (1985).
- [25] Jouhara H., Almahmoud S., Amisha C., Delpech B., Nannou T., Tassou S., Arribas J.J., [Experimental Investigation on a Flat Heat Pipe Heat Exchanger for Waste Heat Recovery in Steel Industry](#), *Energy Procedia*, **123**: 329–334 (2017).
- [26] Xie C.Y., Tao H.Z., Li W., Cheng, J.J., [Numerical Simulation and EXperimental INVEstigation of HEAT PIPE HEAT EXCHANGER APPLIED in RESIDUAL HEAT REMOVAL SYStem](#), *Annals of Nuclear Energy*, **133**: 568–579 (2019).
- [27] Mir T., Singh A., Rana A., [CFD Analysis of Heat Pipe Heat Exchanger to Predict the Temperature Distribution](#), *International Journal of Innovative Technology and Exploring Engineering. (IJITEE)*, **9(4)**: 2670-2675 (2020).
- [28] Brough D., Ramos J., Delpech B., Jouhara H., [Development and Validation of a Trnsys Type to Simulate Heat Pipe Heat Exchangers in Transient Applications of Waste Heat Recovery](#), *International Journal of Thermofluids*, **9**: 100056 (2021).
- [29] Jouhara H., Bertrand D., Axcell B., Montorsi L., Venturelli M., Almahmoud S., Chauhan A., [Investigation on a Full-Scale Heat Pipe Heat Exchanger in the Ceramics Industry for Waste Heat Recovery](#), *Energy*, **223**: 120037 (2021).
- [30] Gupta P.P., Senthilkumar S., & Kang S.W., [Study of Gas-to-Liquid Heat Pipe Heat Exchanger](#), *Processes*, **10**: 808 (2022).
- [31] Rastegar S., Kargarsharifabad H., Rahbar N., Shafii M.B., [Distilled Water Production with Combination of Solar Still and Thermosyphon Heat Pipe Heat Exchanger Coupled with Indirect Water bath Heater – Experimental Study and Thermoeconomic Analysis](#), *Applied Thermal Engineering*, **176**: 115437 (2020).
- [32] Chaudhari V., Dharmadhikari M., Kolhe V., [Performance Evaluation of Heat Pipe Heat Exchanger with Nanofluid: An Experimental Study](#), *Letters in Applied NanoBioScience*, **12(4)**: 121 (2023).
- [33] Jouhara, H., Nieto N., Egilegor B., Zuazua J., González E., Yebra I., Igesias A., Delpech B., Almahmoud S., Brough D., Malinauskaite J., Vlasopoulos A., Hill M., Axcell B., [Waste Heat Recovery Solution Based on a Heat Pipe Heat Exchanger for the Aluminium Die Casting Industry](#), *Energy*, **266**: 126459 (2023).
- [34] Alizadeh, A., Ghadamian H., Aminy M., Hoseinzadeh S., Khodayar Sahebi H., Sohani A., [An Experimental Investigation on Using Heat Pipe Heat Exchanger to Improve Energy Performance in Gas City Gate Station](#), *Energy*, **252**: 123959 (2022).
- [35] Faghri A., [Heat Pipe Science and Technology](#), Global Digital Press, (2016).
- [36] Aqilah F., Islam M., Juretic F., Guerrero J., Wood D., Nasir Ani F., [Study of Mesh Quality Improvement for CFD Analysis of an Airfoil](#), *IJUM Engineering Journal*, **19**: No. 2 (2018).
- [37] Sundén B., Fu J., [Heat Transfer in Aerospace Applications](#), Academic Press, (2016).
- [38] Gawande V.B., Dhoble A.S., Zodpe D.B., Chamoli S., [A Review of CFD Methodology used in Literature for Predicting Thermo-Hydraulic Performance of a Roughened Solar Air Heater](#), *Renewable and Sustainable Energy Reviews*, **54**: 550-605 (2016).
- [39] Gerschenfeld A., Forgione N., Thomas J., [Thermal Hydraulics Aspects of Liquid Metal Cooled Nuclear Reactors](#), Woodhead Publishing, (2019).
- [40] Moukalled, F., Darwish M., Mangani L., [The Finite Volume Method in Computational Fluid Dynamics](#), Springer (2016).

- [41] Rapp B.E., [Microfluidics: Modeling, Mechanics and Mathematics](#), Elsevier (2016).
- [42] Park Y.Y., Jeong Y.S., Park Y.Y., Jeong Y.S., Bang I.C., [Design Study of Heat Pipes for Nuclear Spaceship Applications](#), *Transactions of the Korean Nuclear Society Spring Meeting*, Jeju, Korea, May 23-24 (2019).
- [43] Ahmed N.M., Gao P., Bello S., [Earth and Environmental Science Natural Circulation Systems in Nuclear Reactors: Advantages and Challenges](#), *IOP Conference Series*, **467**: 012077 (2020).
- [44] Dessie H., Kishan N., [Unsteady MHD Heat and Mass Transfer Flow over Stretching Sheet in Porous Medium with Variable Properties Considering Viscous Dissipation and Chemical Reaction](#), *American Chemical Science Journal*, **4(6)**: 901-917 (2014).
- [45] Zeghari K., Louahlia H., [Flat Miniature Heat Pipe with Sintered Porous Wick Structure: Experimental and Mathematical Studies](#), *International Journal of Heat and Mass Transfer*, **158**:120021 (2020).
- [46] Le Q.H., Hussain Z., Khan N., Zuev S., Javid K., Khan S.U., Abdelmalek Z., Tlili I., [Chebyshev collocation Simulations for Instability of Hartmann Flow Due to Porous Medium: A Neutral Stability and Growth Rate Assessment](#), *Ain Shams Engineering Journal*, **14(12)**: 102215 (2023).
- [47] Masuda T., Imai H., Korenaga S., [Thermodynamic Properties of Potassium](#) *Electrical Engineering in Japan*, **105**: No. 6 (1985).
- [48] Poplaski L.M., Benn S.P., Faghri A., [Thermal Performance of Heat Pipes Using Nanofluids](#), *International Journal of Heat and Mass Transfer*, **107**: 358-371 (2017).
- [49] Tlili I., Alkanhal T.A., Rebey A., Henda M.B., Musmar S.A., [Nanofluid Bioconvective Transport for Non-Newtonian Material in Bidirectional Oscillating Regime with Nonlinear Radiation and External Heat Source: Applications to Storage and Renewable Energy](#), *Journal of Energy Storage*, **68**: 107839 (2023).
- [50] Le Q.H., Ali Q., Al-Khaled K., Amir M., Riaz S., Khan S.U., Abdelmalek Z., Tlili I., [Study of Hybrid Nanofluid Containing Graphene Oxide and Molybdenum Disulfide Nanoparticles with Engine Oil Base Fluid: A Non-Singular Fractional Approach](#), *Ain Shams Engineering Journal*, **15(1)**: 102317 (2024).
- [51] Henda M.B., Alkanhal T.A., Rebey, A., Musmar, S.A., Tlili, I., [High-Efficiency Perovskite Photovoltaic System Performance by Molecular Dynamics Method: Optimizing Electron Transport Thicknesses, Hole Transport, and Anti-Reflector Layers of the Sustainable Energy Materials](#), *Engineering Analysis with Boundary Elements*, **150**: 120-126. (2023).
- [52] AlDosari S.M., Banawas S., Ghafour H.S., Tlili I., [Drug Release using nanoparticles in the Cancer Cells on 2-D Materials in Order to Target Drug Delivery: A Numerical Simulation Via Molecular Dynamics Method](#), *Engineering Analysis with Boundary Elements*, **148**: 34-40 (2023).
- [53] Aljaloud A.S.M., Manai L., Tlili I., [Bioconvection Flow of Cross Nanofluid due to Cylinder with Activation Energy and Second Order Slip Features](#), *Case Studies in Thermal Engineering*, **42**: 102767 (2023).
- [54] Banawas S., Ibrahim T.K., Tlili I., Le Q.H., [Reinforced Calcium Phosphate Cements with Zinc by Changes in Initial Properties: A Molecular Dynamics Simulation](#), *Engineering Analysis with Boundary Elements*, **147**: 11-21 (2023).
- [55] Le Q.H., Smida K., Abdelmalek Z., Tlili I., [Removal of Heavy Metals by Polymers From Wastewater in the Industry: A Molecular Dynamics Approach](#), *Engineering Analysis with Boundary Elements*, **155**: 1035-1042 (2023).
- [56] Li C., Tlili I., [Novel Study of Perovskite Materials and the use of Biomaterials to Further Solar Cell Application in the Built Environment: A Molecular Dynamic Study](#), *Engineering Analysis with Boundary Elements*, **155**: 425-431 (2023).
- [57] Gupta S.K., Gupta S., Singh R., [A Comprehensive Review of Energy Saving in Shell & Tube Heat Exchanger by Utilization of Nanofluids](#), *Materials Today: Proceedings*, **50(5)**: 1818-1826 (2022).
- [58] Ahmadi N., Ashrafi H., Rostami S., Vatankeh R., [Investigation of the Effect of Gradual Change of the Inner Tube Geometrical Configuration on the Thermal Performance of the Double-Pipe Heat Exchanger](#), *Iranian Journal of Chemistry and Chemical Engineering (IJCCE)*, **42(7)**: 2305-2317 (2023).

- [59] Moori Shirbani, M., Alavi, S.E., Koochak Tondro M., [Minimizing the Entropic Potential Losses Number in a Gasket-Plate Heat Exchanger](#), *Iranian Journal of Chemistry and Chemical Engineering (IJCCE)*, **42(3)**: 1006-1016 (2023).
- [60] Alavi S.E., Moori Shirbani M., Koochak Tondro M., [Exergy-Economic Optimization of Gasket-Plate Heat Exchangers](#), *Journal of Computational Applied Mechanics*, **54(2)**: 254-267 (2023).
- [61] Alavi S.E., Moory Shirbani M., Koochak Tondro M., [Optimization of Gasket-Plate Heat Exchanger Based on Entransy Principles Using new Method of Harris Hawks](#), *Multiscale and Multidisciplinary Modeling, Experiments and Design*, **6**: 1-14 (2023).
- [62] Warambourg V., Mouahid A., Crampon C., Galinier A., Claeys-Bruno M., Badens, E., [Supercritical CO₂ Sterilization under Low Temperature and Pressure Conditions](#), *The Journal of Supercritical Fluids*, **203**: 106084 (2023).
- [63] Hassan M., Fouad A., Dessoki K., Al-Ghussain L., Hamed A., [Performance Analyses of Supercritical Carbon Dioxide-Based Parabolic trough Collectors with Double-Glazed Receivers](#), *Renewable Energy*, **215**: 118884 (2023).
- [64] Cabeza L., de Gracia A., Fernández A., Farid M., [Supercritical CO₂ as heat transfer fluid: A review](#), *Applied Thermal Engineering*, **125**: 799-810 (2017).
- [65] Hu G., Hu R., Kelly J., Ortensi J., [Multi-Physics Simulations of Heat Pipe Micro Reactor](#), *Nuclear Science and Engineering Division, Argonne National Laboratory, Nuclear Regulatory Commission, Idaho National Laboratory*, ANL/NSE-19/25 (2019).
- [66] Cai, H.-f., Jiang, Y.-y., Wang, T., Liang, S.-q., Zhu, Y.-m., [Experimental Investigation on Convective Heat Transfer and Pressure Drop of Supercritical CO₂ and Water in Microtube Heat Exchangers](#), *International Journal of Heat and Mass Transfer*, **163**: 120443 (2020).
- [67] Ahmadi N., Ashrafi H., Rostami S., Vatankhah R., [Investigation of the Effect of Gradual Change of the Inner Tube Geometrical Configuration on the Thermal Performance of the Double-Pipe Heat Exchanger](#), *Iranian Journal of Chemistry and Chemical Engineering (IJCCE)*, **42(7)**: 2305-2317 (2023).
- [68] Küçük H., [The Effect of Minichannels on the Overall Heat Transfer Coefficient and Pressure Drop of a Shell and Tube Heat Exchanger: Experimental Performance Comparison](#), *International Journal of Thermal Sciences*, **188**: 108217 (2023).
- [69] Ashrafi H., Pourmahmoud N., Mirzaee I., Ahmadi N., [Performance Improvement of Proton-Exchange Membrane Fuel Cells through Different Gas Injection Channel Geometries](#), *International Journal of Energy Research*, **46(7)**: 8781-8792 (2022).
- [70] Matthews C., Laboure V., DeHart M., Hansel J., Andrs D., Wang Y., Ortensi J., Martineau R.C., [Coupled Multiphysics Simulations of Heat Pipe Microreactors Using DireWolf](#), *Nuclear Technology*, **207**: 1142-1162 (2021).