

# Reduction of Dust Output from Prilling Tower of Khorasan Petrochemical Company Using Six Sigma Methodology

**Zourmand, Bahman; Khosroyar, Susan\*<sup>+</sup>; Arasteh Nodeh, Ali; Ghahremani, Hossein**  
*Department of Chemical Engineering, Quchan Branch, Islamic Azad University, Quchan, I.R. IRAN*

**ABSTRACT:** Urea ( $\text{NH}_2\text{CONH}_2$ ) is very important for the agriculture industry as a nitrogen-rich fertilizer. Urea synthesizes from ammonia ( $\text{NH}_3$ ) and carbon dioxide ( $\text{CO}_2$ ) at 170 - 180°C and 143 kg/cm<sup>3</sup>. This study aims to reduce the amount of urea dust from the flue gas emitted from the Urea Prilling Tower of Khorasan Petrochemical Company. Since the conversion process of molten urea to urea seeds produce much dust, a large amount of environmental pollution caused by this industry can be prevented by examining various factors in dust production in this plant. Thus, the project was divided and implemented into six general phases (Six Sigma project), including problem definition and study phase, measurement and estimation of time and cost required, preliminary analysis, design, and implementation (DMAIC methodology). After implementing the plan, a significant reduction in urea emissions was observed, about 38%. Therefore, the results show that Six Sigma is a useful tool that can accurately predict the removal of urea dust from flue gases.

**KEYWORDS:** DMAIC methodology; Emission gas; Environmental pollution; Six Sigma; Urea dust.

## INTRODUCTION

Today, with increasing fugitive dust and greenhouse gas emissions and raising awareness of tighter regulatory laws, dust management has become an important challenge. According to the source and environmental conditions, dust includes any substance in the air harmful to humans, animals, plants, and the environment and impairs human health and general well-being [1]. Dust can lead to global and local climate change, biological, geological, chemical, or environmental changes. Dust particles are divided into two groups regarding their effect on lung health. Inhaled dust particles larger than 10 micrometers are typically caught by the nose, throat, or upper respiratory tract.

In contrast, inhaled dust particles below 10 micrometers can penetrate the body's natural cleansing

mechanisms and settle deep into the lungs [2]. Dust conditions and their control methods are influenced by production techniques and technologies, system options, equipment options, and differences in the design and construction of conveyors. Due to the variety of dust control methods, in evaluating the causes of dust production, dust production processes, and potential management techniques must be considered to achieve optimal performance.

Nitrogen (N), phosphorus (P), and potassium (K) are more effective than other known elements in plant growth. Therefore some compounds containing these elements are used as chemical fertilizers in agriculture [3,4]. With its chemical formula  $\text{NH}_2\text{CONH}_2$ , Urea is the most popular

\* To whom correspondence should be addressed.

+ E-mail: [susankhosroyar@yahoo.com](mailto:susankhosroyar@yahoo.com)

1021-9986/2022/9/3045-3063

19/\$.09

nitrogen fertilizer. Its advantages include compatibility for most plants, especially all grains, no change in soil salts concentration, and not leaving salt compounds in the soil [5]. Today, industrial urea is one of the most widely used products globally. More than one hundred years have passed since the production of industrial urea in the world, and different methods have been invented for the production of urea, and new technologies are used continuously. The technologies used to produce industrial urea each have their advantages and disadvantages. The main method of producing industrial urea is the reaction between ammonia and carbon dioxide, and all commercial-industrial urea in the world is produced from this method [6].

Khorasan Petrochemical Company Urea Unit is designed based on 1500 tons of urea per day. After the melamine unit was put into service, changes were made based on 1700 tons per day production.

The urea synthesis process is as follows; Liquid ammonia enters the ammonia pump from outside the unit, and its pressure increases to  $163 \text{ kg/cm}^3$ . Carbon dioxide enters the  $\text{CO}_2$  compressor from outside the unit with a small amount of air and compresses to its pressure increases to  $146 \text{ kg/cm}^3$ . High-pressure Ammonia and carbon dioxide enter the HP condenser carbamate, producing ammonium carbamate. In the urea unit reactor, ammonium carbamate is converted to urea and water, according to the following Reactions [3]:



The first reaction is highly reactive and exothermic, and the second is slow and endothermic. Carbon dioxide is produced during the production process of ammonia or hydrocarbons such as natural gas and petroleum products, which means the direct production of urea from natural raw materials.

This study aimed to optimize the urea unit synthesis process parameters and reduce the urea dust in the exhaust air from Khorasan petrochemical, the Prilling Tower. With the advancement of technology globally, industrial urea has found many applications; however, industrial urea is mostly used in agriculture [7]; it is also used in the production of other industrial products such as pharmaceuticals, melanin production, adhesives, laminates, foundry compounds, coatings, and textile fabrics [8,9].

Most urea production plants in the world have Prilling Tower. Prilling is the most effective way to produce uniform spherical particles from liquid solutions. It involves two operations: first, producing liquid droplets, and second, solidifying them falling by cooling as the air flows through the tower. The prills are almost spherical, relatively hard, and nonporous with no fragmented shells. Prilling is classified as a specific type of granulation [10]. Prilling Towers have high operating costs, and most of them must be equipped with wet scrubbing to prevent the production of a lot of dust [11]. The main reasons for dust production in Prilling Towers are great height (45–60 m) and forced convection airflow [12,13]. Many types of research have been done or are being done to remove emitted dust from the flue gas of Prilling Towers worldwide. For the prilling and granulation processes, parameters such as pressure and temperature are of initial importance and need to be kept constant [14]. The production of monodispersed crystals plays a major role in reducing dust emission in Prilling Towers [15]. *Gezerman* (2012) proposed an effective technique based on chemical precipitation to prevent ammonia emission [16]. *Saleh et al.* (2015) developed a design methodology for the prilling process and selected special showerhead spray to reduce carryover, which was backed up by The Computational Fluid Dynamics (CFD) simulation [17]. *Skydnenko et al.* (2017) used a vibratory granulator to investigate liquid jet breakup into droplets and provided prills with a narrower size range, resulting in a substantial reduction in dust emission [18]. *Styring et al.* (2019) produced Blue Urea using attenuated reaction conditions and hydrogen derived from renewable-powered electrolysis to produce a reduced-carbon alternative, in this method, reduced dust and costs [19]. *Pacheco et al.* (2019) evaluated coated urea production's technical and environmental aspects in a spouted bed to control nitrogen volatilization [20]. Using at least one venturi scrubber decreased the urea dust with a lower pressure drop over the scrubber [21].

Based on particle adsorption theory, *Wang et al.* developed a new numerical simulation method to study the effective removal of particulate matter from the flue gas emitted from Urea Prilling Tower and examined the effect of factors such as gas-phase rate, spray density, particle, and droplets size. The results showed that the particle removal efficiency above ten  $\mu\text{m}$  could reach 97%. However, the removal efficiency of particles less than

ten  $\mu\text{m}$  decreases with decreasing particle diameter due to the random movements of this small particle. Based on this numerical simulation, it is necessary to design a spray scrubber for optimal design in practical engineering applications [22].

Therefore, the purpose of this work is to evaluate the factors affecting dust generation in the urea Prilling Tower of Khorasan petrochemical company by Six Sigma methodology. Six Sigma is a data-driven method that provides tools and techniques for defining and evaluating each step [23]. This method offers ways to improve the efficiency of a business structure, improve process quality and increase low profits [24]. By summarizing the stages of urea production, various factors in creating dust are investigated. 1- Urea synthesis; Compression of ammonia and carbon dioxide. 2- Purification; the major impurities in the composition are water from the urea synthesis process and unreacted substances (ammonia, carbon dioxide, and ammonium carbamate). 3- Concentration of the urea solution at about 75% w/w is concentrated to give molten urea at 99% w/w and 140°C. 4- Prilling and granule; Urea fertilizer is sold in granules with 2 to 4 mm diameter. These granules are formed by spraying molten urea into the granular chamber. Dried and cooled granules are classified using screening plates [22, 25].

Urea dust is related to the fragility of urea seeds. The most effective way to reduce urea dust is to lower the moisture content of the product because water will loosen urea seeds. The uniform production of urea grains by urea spraying bucket will cause the proper distribution of grains and thus reduce urea dust [26]. In general, factors such as humidity, biuret increase and temperature of molten urea, the rotation speed of the bucket, temperature and humidity of the inlet air, how cyclones work, the high air velocities affect urea dust [27] are very important. It takes a lot of time and money to stop production and check all the parameters. Therefore, using a special and scientific method to reduce dust is reasonable and valuable during normal operation. Six Sigma's method in quality management is trying to get as close as possible to the degree of development and excellence in production and service delivery. This approach aims to reduce the desired state or variability of process outputs. This method has not been used in similar units, generating revenue, reducing dust, and improving environmental conditions. It is hoped that this method can reduce environmental problems and

increase productivity and income in Khorasan Petrochemical Complex and similar industries by reducing dust.

## EXPERIMENTAL SECTION

### Materials

Prilling Tower feed is molten by urea containing 98.5% wt urea, 0.88% biuret, less than 0.3% wt water, and about 170 ppm ammonia at a temperature of about 149 ° C. Prilling Tower with a height of 90 m and a diameter of 17 m includes:

- 1- Four cyclones to collect urea dust from the air,
- 2- Scrubber to collect urea on the floor of the Prilling Tower,
- 3- Belt for transfer urea to warehouses,
- 4- Four fans at the top of the tower to transfer air through the tower to the atmosphere,
- 5- A suction fan to transfer air into the tower for cooling,
- 6- Twenty-six fin fan heat exchangers around the tower for heating in winter,
- 7- Two types of exchangers for heating the inside air in winter and cooling in summer,
- 8- Two types of filters to remove moisture, and
- 9- Impurities from the intake air. The urea pump is P-4140 that transfers the diluted urea solution of the D-4140 drum to the molten urea tank (TK-4104). Bucket SR-4101 A/B is a cylinder with a very special design with small holes and is made by KBR company depending on capacity from 190 to 230 rpm. The PFD, the flow diagram of the synthesis section, and the Prilling Tower of the urea unit are shown at the end of this article (Figs. 9, 10, 11). Dust measuring device (online) PCME Ltd model SYS3701-01 PC-ME and DUST TOOLS software were used. Version 16 Minitab-generated interpretations (T and W test) were used to understand and respond to the statistical analysis

### Methods

The urea unit was obliged to take the necessary proceedings to reduce the urea dust from the flue gas emitted from Prilling Tower from 178 mg / Nm<sup>3</sup> to 110 mg / Nm<sup>3</sup>.

The project was divided into six general phases (66) and implemented. It is a method of continuous quality improvement done by reducing the inherent changes in the process [28,29]. According to Fig. 1, the methodology used in this paper is DMAIC, which is a five-step improvement process like Define, Measure, Analyze, Improve, and Control (DMAIC) [30].

First, the SIPOC design was reviewed [32,33]. SIPOC includes Suppliers, Inputs, Processes, Customers, and

Table 1: SIPOC analysis for reduction of dust output from Prilling Tower.

Suppliers	Inputs	Processes	Customers	Outputs
Urea unit Power plant unit Ammonia unit Environment	Materials Equipment Human resources Basic information	How to produce urea dust How to get rid of urea dust	Urea warehouses Loading units Agricultural Services companies.	Urea dust Moisture Qualitative and quantitative Datalog sheets

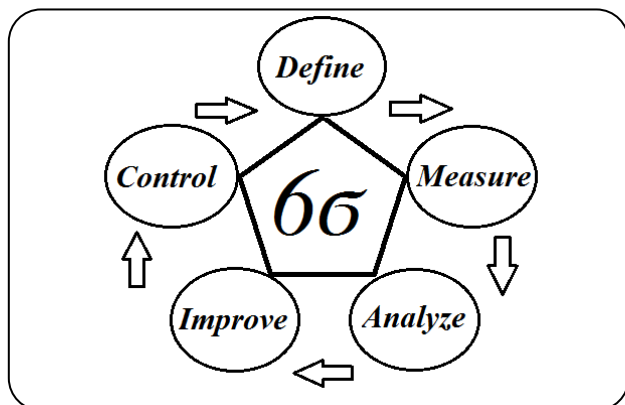

Fig. 1: DMAIC methodology of six sigma phases (6σ) [31].

Outputs. SIPOC diagrams for this project are shown in Table.

#### Problem definition and study phase (Effective factors on the urea dust in Prilling Tower)

In general, the effective factors on the urea dust can be divided into two general parts [34]:

#### Influencing factors related to molten urea on the amount of dust

1- Urea is produced according to the following reaction:

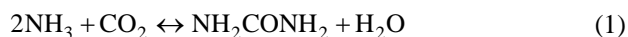

If the urea production reaction does not have the required efficiency, in the molten urea solution, the output of the evaporator will increase the moisture content, increasing the humidity will reduce the mechanical strength of solid urea granules to excess dust [35,36].

2- Biuret increase: According to the following reaction, one of the side reactions in the urea production process is biuret formation.



In addition to being an undesirable product in the urea production process, its increase causes an increase in the

amount of dust coming out of the fans of the Prilling Tower; controlling the factors affecting the increase of biuret is of special importance.

Factors that influence the amount of product biuret are decreased ammonia concentration, increased urea concentration, high residence time, and high temperature of urea solution [37].

3- Temperature control of molten urea solution: Increasing the temperature of urea solution increases biuret. Also, the high abnormal temperature of the urea solution reduces the mechanical strength of the urea grains, which in turn increases the amount of dust at the outlet of the fans of the Prilling Tower due to the brittleness of the grains [38].

4- High operating pressure of the unit low-pressure section: If the operating pressure in this section is higher than normal, the separation of ammonia and carbon dioxide is practically not done well and ultimately reduces the concentration of molten urea in the evaporator outlet, and this increases the amount of dust in the outlet of the fan of the Prilling Tower.

#### Influencing factors related to Prilling Tower on the amount of dust

1- The high rotation speed of the bucket causes the production of very small grains of urea, which creates dust. The small grains of urea that are still liquid, when they hit the inner wall of the upper part and the roof of the tower, are formed as lumps, and over time, the sticking urea is transferred to the environment in the form of dust along with the exhaust air from the tower.

2- The low rotation speed of the bucket increases the grain size, making it difficult for water molecules to escape from the urea grains. As a result, the grains do not have the necessary strength, producing dust by breaking the grains [17]. The high temperature of the inlet air to the Prilling Tower causes an increase in the temperature of urea grains and reduces its resistance, increasing the dust.

3- The temperature of the urea solution introduced into the Prilling Tower is about 140°C; the excessive

low temperature of the inlet air to the Prilling Tower causes a temperature shock to urea grains, increasing the dust.

4- If the cyclones do not work well, large amounts of small urea particles are transferred to the Prilling Tower by the incoming airflow, increasing the dust [38]. One of the problems of cyclones is the clogging of their inner walls with urea, which is due to the difference between the temperature of the metal wall of the cyclone and the temperature of urea dust [39]. In this case, it is impossible to remove small grains of urea in the cyclones and cause the transfer of dust and very small grains of urea into the tower with the incoming air, which increases the amount of dust in the outlet the fan of the Prilling Tower.

5- The study shows that urea from cyclones to the urea production cycle increases the amount of dust.

6- The humidity of the inlet air to the Prilling Tower increases the humidity of urea grains; in this case, the mechanical strength of the grains is reduced, which increases the amount of dust.

7- Whatever the moisture content of the molten urea solution, the dust increases. Increasing the moisture content reduces the mechanical strength of urea seeds. Therefore, with the fall of seeds from a height of 80 meters from the Prilling Tower, their fragility increases and dust increases[40].

8- Whatever the inner surface of the Prilling Tower be smoother, the possibility of hitting the seeds to the surface will be less, and it decreases the amount of dust [41]. The unevenness of the surface causes different movements in the descending grain and reduces the strength of the grain, causing it to break and, as a result, add dust to the tower. Therefore, to prevent this problem, the inner surface of the walls is covered with a suitable color. The floor of the tower is made of polished ceramics to minimize the amount of dust created by the smooth inner surface.

9- Clogging of the bucket holes makes it difficult to distribute the output stream of urea solution out into the Prilling Tower. The urea seeds stick to each other, and the drying operation of the seeds is incomplete, and then the dust increases.

10- The inlet air control to the Prilling Tower is of special importance. Proper control ensures that the drying operation of urea grains is done well, and the quality of the grains is such that the amount of dust is minimized. Excessive inlet air increases dust [42].

### ***Implementation of the measurement phase and quantitative estimation of dust reduction***

In the amount of dust coming out of the fans of the Prilling Tower, in addition to internal factors, environmental factors such as humidity and temperature are also effective. In manufacturing systems, achieving one or more temporary results may not be a good response to improvements in the system. So, the results are considered in the long run. A period of 2 months is enough time for the results of this activity to be sustainable.

At this stage, the output information of the prilling unit is measured quantitatively over a two-month period, which includes the measurement of dust, air humidity, speed, and humidity of the output product.

### ***Implementation of analysis phase and identification of dust reduction***

In the analysis process, measurement, materials, personnel, machines, method of analysis, and environmental factors are modules that are detailed in Fig. 2.

### ***Implementation of the innovation and initiative phase of dust reduction***

How to prioritize and choose the solution of dust reduction based on performance risk criteria, side effects on the process, simplicity of the solution, speed of response, no need for new equipment and devices, effectiveness and cost of implementation, done according to quantitative criteria.

### ***Implementation of the design control phase in the implementation of dust reduction***

In this phase, it is necessary to anticipate all possible ways of rejecting the modified process. All factors affecting the amount of dust are identified and monitored carefully, then measured during operation for a long time (at least two months). The root of these problems must be found and solved.

## **RESULTS AND DISCUSSION**

Quantitative information on the output of the prilling unit was measured before the correction in a two-month interval (Table 1). The maximum, minimum, and average amount of the measured urea dust in the exhaust air of the prilling section is 183 mg/Nm<sup>3</sup>, 130 mg/Nm<sup>3</sup>, and 148.31 mg/Nm<sup>3</sup>, respectively. The standard distribution

**Table 1: Quantitative information of urea dust in the exhaust air of the prilling unit.**

Dust (mg/Nm <sup>3</sup> )	Product temperature on the conveyor (°C)	Humidity of entrance air	The flow of urea solution to the evaporator (ton/hr)	Vacuum of the Second stage (mmHg)	Bucket Speed (rpm)	Bucket Type	Urea Pump	PLC Condition	Air control valve	Product moisture
180	47	51%	93	30.9	234	A	ON	ON	31.3	0.29
150	45	57%	94	31.5	234	A	OFF	ON	35	0.29
183	45	24%	101	32	246	B	OFF	ON	51	0.25
160	38	41%	102.5	33.8	250	B	OFF	ON	33	0.29
140	37	48%	91.5	36	239	B	OFF	ON	11	0.26
140	44	55%	93	29	227	B	ON	ON	67	0.3
148	44	46%	92.5	31	227	B	OFF	ON	90	0.3
140	47	49%	93	28.5	240	B	OFF	ON	61	0.24
160	47	36.5%	93	28.5	240	B	OFF	ON	49	0.3
140	44	51.8%	96	33.4	240	B	OFF	ON	56.8	0.35
130	46	53%	93	31	240	B	OFF	ON	58	0.3
160	42	51%	92	33	240	B	ON	ON	51	0.3
140	43	48%	92.5	29	240	B	OFF	ON	56	0.3
130	49	38.5%	97	32	241	A	OFF	ON	54	0.33
160	44	72%	94	29	241	A	OFF	ON	73	0.33
160	48	38%	90	21.5	226	A	OFF	ON	71	0.28
150	43	30%	93	29.5	226	A	OFF	ON	67.5	0.26
130	42	38%	92	28.5	226	A	OFF	ON	66.5	0.29
140	45	46%	93.5	30.5	235	A	ON	ON	66.5	0.3
140	47	31%	93.5	29.8	235	A	OFF	ON	64	0.29
160	44	39%	92.5	32	235	A	OFF	ON	66	0.34
140	47	31%	91.9	33	235	A	OFF	ON	57	0.29
160	45	65%	92.4	31.5	235	A	ON	ON	63	0.4
160	45	65%	92.4	31.5	235	A	ON	ON	63	0.4
140	45	39%	91.6	31.2	236	A	OFF	ON	64	0.29

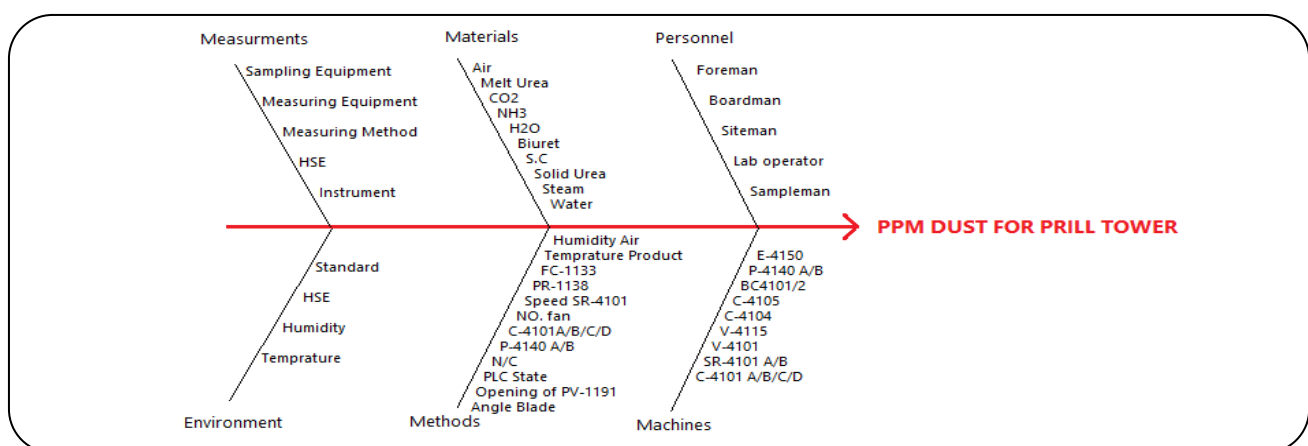

**Fig. 2: Factors influencing the implementation of analysis phase and identification of dust reduction..**

of values is 207.5. The DOE, REGRESSION, CORRELATION, CONTROL CHARTS, and ANOVA were used in the manuscript [43, 44].

Table 2 parameters include 1- the second column parameter (Product temperature on the conveyor ( $^{\circ}\text{C}$ )): According to the design, lower and upper limits are between 30 - 50  $^{\circ}\text{C}$ , and the operating range is controlled between 35 - 49  $^{\circ}\text{C}$ . It should be noted that the temperature of the product depends on factors such as being a service of the PLC and changes in ambient temperature. 2- The third column (Humidity of entrance air is an important factor in changing the humidity of urea product) (to increase the quality of the product should be less than 0.3%): Low and high values are 15% and 80%, respectively. The operating range is between 18% and 72%, depending on the region's environmental conditions. 3- The fourth column (The flow of urea solution to evaporator ( In fact, the SR bucket speed is regulated and controlled by the flow rate of molten urea)): Low and high values are 85 and 105 ton/h, respectively, and the operating range is between 89 and 102.5 tons/hr. 4- The fifth column (Vacuum of the second stage (Having a direct effect on product moisture)): Low and high values are 20 and 38 mmHg, respectively, and the operating range is between 21.5 and 36 mmHg. Vacuum is a function of water concentration in the urea mixture and clogging of the ejector booster. 5- The sixth column (Bucket Speed): Low and high values are 180 and 280 rpm, respectively, and depending on the operating conditions and the amount of urea flow, the bucket speed is controlled between 205 and 250 rpm. 6- The seventh column (Bucket type( a device for spraying molten urea into the tower, the higher the feed, the higher the SR speed)): There is no specific restriction on the service of the bucket type, and the bucket is replaced when the product quality is reduced or repair the bucket and related equipment. 7- The eighth column (Urea pump (the P-4140 pump that transfers the diluted urea solution of the D-4140 drum to the molten urea tank (TK-4104))): This pump should be serviced when more than 60% urea solution is stored. The flow rate of the urea pump is between 1 to 8 tons/h, which according to experience, has been the optimal flow rate between 2 to 3 tons/hr. 8- The nine columns: According to the design, the PLC system (the instrumentation system that performs the Prilling Tower service program) must be in service. In addition to

controlling the temperature of the urea product, the dust of the prilling tower product led to the cyclones and collected in a drum, and then urea solution is prepared. 9- The ten column (Air control valve (the control valve XV-1040 keeps the product temperature around 40 $^{\circ}\text{C}$ ): The opening of the control valve of the inlet air to the tower is between 0 and 100%, but according to the control results, the opening of this control valve is between 15 to 90%. 10- The eleven column (Product moisture): The moisture content of the product depends on several factors. According to the operational parameters, the product's moisture content is between 0.25 to 0.4%, which is the lower and upper limit between 0.2 and 0.42%.

The normal percentage probability plot of dust, the bell plot of normal distribution, and other statistical studies are shown in Fig. 3. The parameters related to Six Sigma include 1- The Upper Control Limit (UCL) and the Lower Control Limit (LCL), 2- Process Capability Index (Cpk) is a short term process index, 3- Ppk is long term indicator. There must be a starting point to measure improvement (or lack of it). This is called the baseline measurement. After the improvements, the process is measured again, and a new Cpk value is calculated in the CONTROL phase. The Cp is commonly referred to as the process entitlement because it represents the best possible performance when controlled.  $P < 0.5$  indicates that the difference between the measured values is not significant, and in other words, these data are not normal. The data's abnormality can be seen in the second and the bell plot's examination. For this reason, the observed within performance function is used, which is equal to 995591. A negative Cpk indicates that the mean is out of tolerance, and according to the Sigma table, the Sigma level is zero [45].

The normal plot shows we cannot use the assumption of normally for data, so instead of Cpk, we can refer to Ppk (Ppk is the process capability without normal assumption) [46].

The service status of the P-4140 pump, the type of SR-4101 bucket on the amount of dust, and the mentioned relations and shapes are also related to Six Sigma are shown in Fig. 4. When the P-4140 pump is in service, the dust on the top fans of the Prilling Tower increases. The type of SR-4101 bucket does not affect the amount of dust. Clogging some of the bucket holes will increase the output current from other holes, increasing the dust.

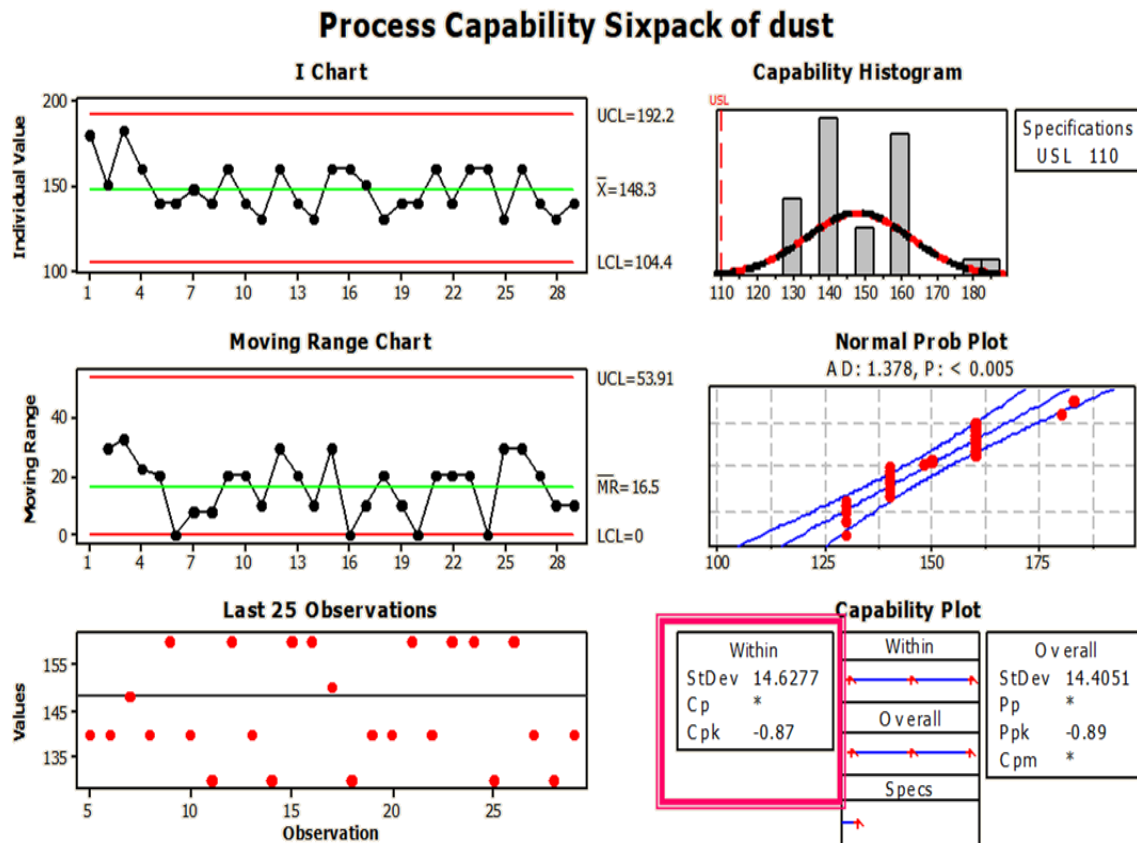

Fig. 2: Statistical review of quantitative information of prilling dust before correction.

According to Fig. 5, data analysis shows the effectiveness of all factors on dust output, the relationship between the factors of influence with the help of regression equations is shown. P-value=0 indicates the significance of the model.

According to the studies, the factors listed in Table, affect the amount of dust output, and the decision on how to affect it has been determined. R-squared indicates how well the regression model fits the data. Specifically, it measures how much of the variation in the response. Y (dust) is explained by the X variables in the regression model. The higher the R-squared value, the better the regression model fits the data 42% as variation in the dust can be explained by the regression model. R-Sq<0.7 means that the parameter has a low to moderate effect, and since most of R-Sq is obtained around 0.4, most parameters have a low to moderate effect. Although the R-Sq is not very high, the low R-Sq may indicate that all parameters affecting the amount of dust were not identifiable due to the complexity of the process.

In this Table, AC-1050 is humidity meter analyzer in the inlet air duct path, H2O Product is moisture in the product, PV-1191 is airflow control valve from fluidized bed to cyclones, P-4140 is urea solution transfer pump of D-4120 drum to molten urea tank, PR-1138 is the second stage evaporator pressure gauge, Speed SR-4101 is the speed of bucket SR-4101, FC-1133 is a mass flow controller meter to the first stage evaporator. TI-1065 is a urea path thermometer on the product belt.

The method of prioritizing and selecting the solution to reduce the output dust was done according to the quantitative criteria shown in

In this Table, the parameters affecting the amount of dust have been identified. Using the regression method, removing each parameter that caused the dust has been presented.

The proposed solutions chose the output flow of pump P-4140, slow discharge D-4120, and minimum condensation during discharge. The prioritization matrix of the mentioned solutions is shown in Table 5, equal to 1376, 1247, and 1290, respectively.



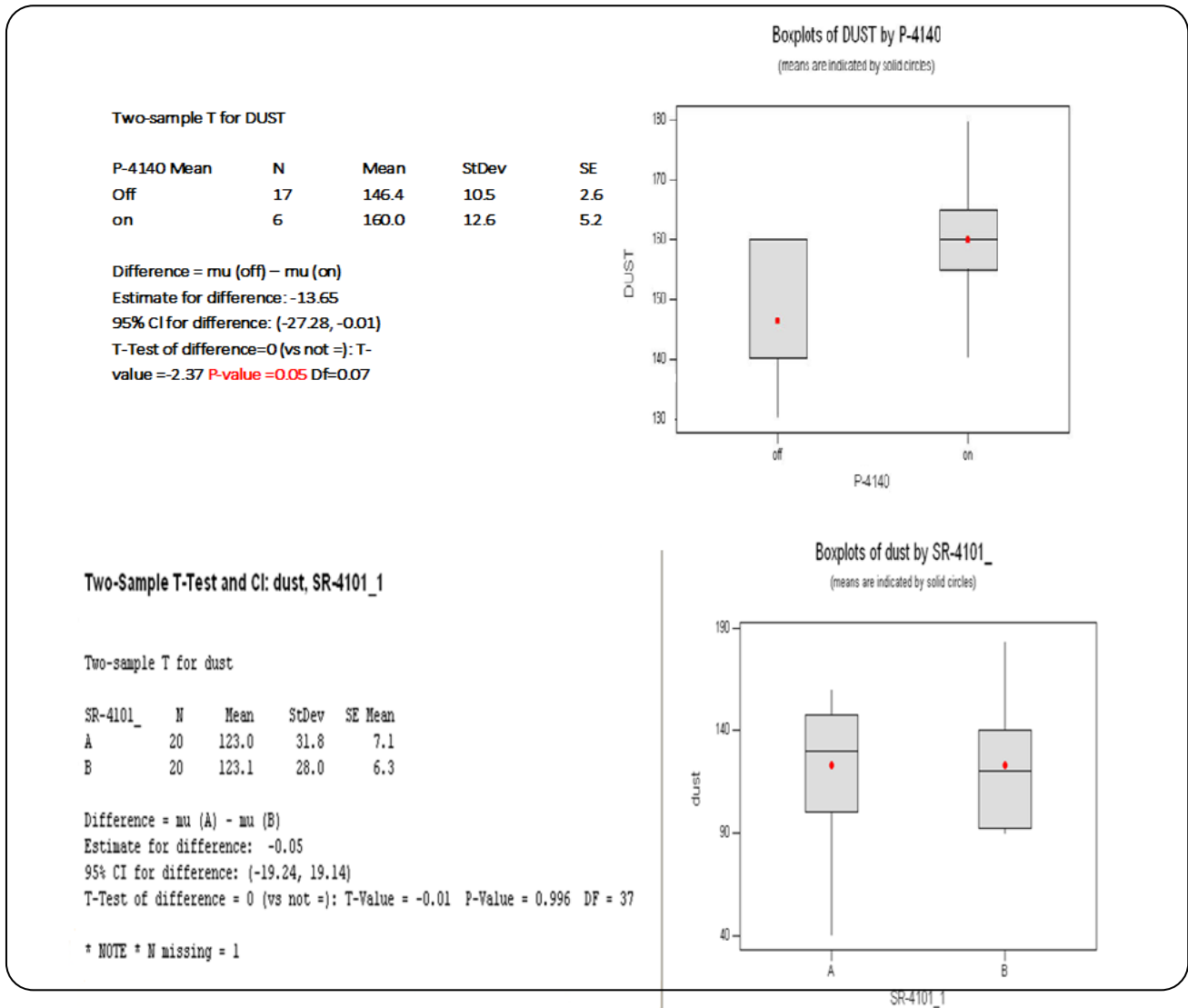

**Fig. 4** Statistical analysis: a) difference between the P-4140 pump and the outlet dust, b) difference between the SR4101 pump and the outlet dust.

After the studies on dust reduction, the most effective variables on dust reduction were determined. By changing one variable and keeping the other variables constant, the effect of that variable on dust reduction was determined; the results are shown in Table.

Because the bucket speed of SR-4101 is directly related to the amount of molten urea, we know that increasing and decreasing the bucket speed affects the quality of the product. In the optimal state, the bucket speed of SR-4101 with a 72% urea solution mass flow rate is determined by the operational test, shown in Table. Reducing the SR-4101 from 245 to 206 rpm requires periodic control. To optimize the rotation speed of the

bucket, Mark obtained the optimum droplet size between 1.5 and 2.5 mm [47].

In this plan, the project's scope is related to a tower, and it cannot be divided into different components. Thus the solution is fully implemented and does not require a pilot. After determining the factors affecting the dust of the Prilling Tower according to Table 2 for each factor, the selected solution, control method, control period, and responsible for doing, are determined.

Dust output characteristics were measured again over two months to determine the accuracy of the studies. The results are shown in Table 9.

**Table 2: Effective factors on the amount of dust and ways to reduce and eliminate it.**

Probable cause	parameter	Indicator	Method	Decision
The humidity of entrance air to the fluidized bed cooler	AC-1050	R-Sq=42%	REGRESSION	Ambient humidity is effective on the amount of dust.
Product moisture	H <sub>2</sub> O Product	R-Sq=42%	REGRESSION	Product moisture is little effect on the amount of dust.
Opening of the outlet of cyclones air control valve	PV-1191	R-Sq=42%	REGRESSION	The degree of openness of the PV-1191 is effective on dust.
Urea solution Pump	P-4140	P=0.05	ANOVA	Turning on the pump is effective on the amount of dust.
Vacuum of the second stage of the evaporation section	PR-1138	R-Sq=42%	REGRESSION	The second stage vacuum is effective on the amount of dust.
Bucket Speed	Speed of SR-4101	R-Sq=42%	REGRESSION	High speed is effective on the amount of dust.
The flow of the evaporation section feed	FC-1133	R-Sq=42%	REGRESSION	High flow is effective on the amount of dust.
Fan number	Fan number	P=0	2-Sample t	The number of fans is effective on the amount of dust.
Product temperature on the conveyor	TI-1065	R-Sq=42%	REGRESSION	The high product temperature is effective on the amount of dust.

**Best Subsets Regression: dust versus Ac1050, FC-1133, ...**

Response is dust

40 cases used 1 cases contain missing values.

Vars	R-Sq	R-Sq(adj)	C-p	S	F	P	S	O
1	43.4	41.9	1.7	22.542				X
1	28.3	26.5	11.7	25.354	X			
2	46.3	43.4	1.7	22.234	X		X	
2	44.8	41.8	2.8	22.555			X	X
3	47.8	43.5	2.8	22.228	X	X		X
3	47.5	43.1	3.0	22.305	X	X	X	
4	50.1	44.3	3.3	22.055	X	X	X	
4	48.9	43.0	4.1	22.317	X	X	X	X
5	50.2	42.9	5.1	22.335	X	X	X	X
5	50.2	42.9	5.2	22.344	X	X	X	X
6	50.5	41.5	7.0	22.621	X	X	X	X

**Regression Analysis: dust versus Ac1050, FC-1133, ...**

The regression equation is

$$\text{dust} = - 242 + 0.598 \text{ Ac1050} + 2.07 \text{ FC-1133} - 1.52 \text{ PR-1138} + 0.899 \text{ SR-4101} + 0.120 \text{ opening} - 44 \text{ wet}$$

S = 22.62      R-Sq = 50.5%      R-Sq(adj) = 41.5%

**Analysis of Variance**

Source	DF	SS	MS	F	P
Regression	6	17200.0	2866.7	5.60	0.000
Residual Error	33	16887.0	511.7		
Total	39	34087.0			

Source	DF	Seq SS
Ac1050	1	9659.7
FC-1133	1	3679.0
PR-1138	1	506.6
SR-4101	1	3216.4

**Fig. 5: Statistical relationships governing the output dust.**

**Table 3: Prioritization in the selection criteria of general solutions to reduce output dust.**

Criteria	Sum	percentage
Implementation risk	8	0.186
Side effects on the process	7	0.162
The simplicity of the solution	9	0.210
Speed of response	9	0.210
No need for new equipment and devices	1	0.023
Effectiveness level	8	0.186
Cost of implementation	1	0.023
Sum	43	1

**Table 4: Prioritization matrix of outlet dust reduction solutions.**

Solution	(Maximum effect 10 - Minimum effect 1) Criteria and weights							
	Risk	Side effects	Simplicity	Speed	Equipment	Effectiveness	Cost	
	8	7	9	9	1	8	1	
Adjustment of the Pump discharge rate	256	224	288	288	32	256	32	1376
Slow discharge of D-4120 dram	232	203	261	261	29	232	29	1247
Use a minimum of condensate when draining the powder.	240	210	270	270	30	240	30	1290

**Table 5: The risk assessment of exhaust dust reduction solutions.**

Root cause	solution	Risk	The final solution	Documentation
Urea solution Pump	Reduce the pump output	Reduce the rate of depletion and accumulation of urea dust	Concentration adjustment of drum, The pump has been in service for a long time	
Bucket speed	The proportion between round and flow evaporation	Urea overflow of the basket	Reduce the round due to urea flow	According to Table 1
Vacuum of the Second stage of the evaporation section	Adjust the steam to the ejector booster, taking into account the humidity of the product	Increasing the amount of water in the product and clumping it in storage	Pressure control about 30 MMHG	According to internal urea standards, the normal vacuum range is 20 to 65 MMHGA
The flow of the evaporation section feed	The proportion between flow and level of molten urea storage tank	-Increase urea tank level and increase biuret in the product - Decrease urea capacity	Simultaneous control of urea storage tank level and evaporation flow	According to the design, the molten urea tank has two parts, and urea enters the small part of the tank to prevent biuret formation.
Opening of the outlet of cyclones air control valve	Proportional opening of the control valve with the Fluidized Bed Cooler vacuum and urea production dust	Increase dust in the urea production	Fluidized Bed Cooler vacuum control up to 0.5 mmHg	According to internal urea standards, the Fluidized Bed Cooler normal vacuum range is 0.5 to 5 mmHg

**Table 6: Relationship between molten urea flow (FC-1133) and its suitability with SR-4101 rpm.**

Row	FC-1133 (ton/h)	Speed SR-4101 (rpm)
1	88-92	205
2	92-95	215
3	95-98	220
4	98-101	240

**Table 2: Control stages of the dust reduction process with the period and method of control.**

Effective factor	Selective solution	control method	Responsible to do	Control period
The humidity of entrance air to the fluidized bed cooler	Humidity can be reduced by heating the air during the cold and cooling the air during the heat.	By opening steam to entrance air temperature control valves in winter and by opening ammonia to FES from the site in summer	Shift work Supervisor	During each shift
Product moisture	Adjust the consumption in ejectors 2 and 5 and control of urea concentration of tank 4104	Treatments based on the results of Prilling Tower urea routine tests.	Shift control room senior and shift work Supervisor	Product moisture is measured during the shift at least twice.
Opening of the outlet of cyclones air control valve	Vacuum control FBC to least 0.5 mmHg	The operator defines the vacuum value from the DCS board	Shift control room senior	Monitoring during shift
Urea solution Pump	Adjust the concentration of D-4120 - The pump has been in service for a long time	Use less SC when unloading	Shift control room senior	Controlling when the pump is in service
Vacuum of the Second Stage of the evaporation section	Pressure control PR-1138 about 30MMHG	By setting J-4103 from the site location	Shift control room senior and shift work Supervisor	Monitoring during shift
Bucket Speed	Reduce the speed according to the urea flow	Reduction of speed by the operator	Shift control room senior and shift work Supervisor	Monitoring during shift
The flow of the evaporation section feed	Keep constant the evaporation flow	Gradually decrease or increase as needed	Shift control room senior	Monitoring during shift
Product temperature on the conveyor	Prevent the reduction of urea temperature by heating the air	By opening the steam to the TC-1301/05 in the cold season	Shift control room senior	Monitoring during shift

The normal percentage probability plot of dust, the bell plot of normal distribution, and other statistical studies after correction are shown in Fig. 6. According to the P-value, it can be assumed that the data follow a normal distribution. The process performance capability was recalculated at the end of the study and after performing the necessary corrective actions. As shown in Fig. 6 ( $p > 0.1$ ), the new distribution function can be considered normal, so the corresponding  $c_{pk}$  and ppm are used to calculate the sigma level. In the amount of  $\text{ppm} = 240,000$  lesions, the final sigma level was 2.2; the initial sigma

level was below 1, which shows a very good improvement.

Fig. 7 confirms the normal distribution of data after corrections. After the changes, the control range is completely controlled and is always between the LCL and UCL control values.

Fig. 8 shows the percentage of product dust before and after the change, about 0.16 before and less than 0.1. This figure shows a substantial improvement in the process, and the P-value is also significant. Product dust is directly related to the exhaust dust of the prilling fan. The vertical axis shows the amount of dust.

**Table 8: Quantitative information of urea dust in the exhaust air of prilling section after correction.**

Dust (mg/Nm <sup>3</sup> )	Product temperature on the conveyor (°C)	Humidity of entrance air	The flow of urea solution to the evaporator (ton/hr)	Vacuum of the Second stage (mmHg)	Bucket Speed (rpm)	Bucket Type	Urea Pump	PLC Condition	Air control valve	Product moisture
125	44	34%	97	33	237	A	ON	ON	45	0.27
140	40	42.5%	92	26	239	A	OFF	ON	42	0.29
140	45	23%	93	27	239	A	OFF	ON	52	0.29
120	44	38%	90.5	29.5	239	A	OFF	ON	56	0.30
110	42	37%	91.5	28.5	240	A	OFF	ON	61	0.24
110	38	39%	92	29	228	B	ON	ON	46	0.36
100	40	27%	94	30	230	A	OFF	ON	63	0.28
40	36	30%	92	29	230	A	OFF	ON	51	0.29
100	40	47%	93	26	216	A	ON	ON	73	0.23
100	36	22.5%	89	28.5	206	A	OFF	ON	42	0.35
110	44	28%	91	26.5	205	B	OFF	ON	52	0.24
90	39	32%	92.3	30	209	B	OFF	ON	47	0.28
110	42	31%	99	30.8	229	B	OFF	ON	55	0.29
90	43	16%	93.5	29.5	217	B	OFF	ON	57	0.34
90	40	23%	91.8	30	208	B	OFF	ON	59	0.25
80	46	21%	90.5	32.5	206	A	OFF	ON	42	0.29
80	35	18%	91	30	207	A	OFF	ON	47	0.35
100	42	22%	92	28	207	A	OFF	ON	15	0.28
110	38	22%	98	31	228	B	OFF	ON	49	0.29
130	40	24%	93.5	30	205	B	OFF	ON	45	0.34
140	38	26%	91.9	28	205	B	OFF	ON	51	0.27
110	42	41%	92	25	205	B	OFF	ON	74	0.25
100	35	24%	92	29	206	B	OFF	ON	43	0.29
90	36	18%	92	30	206	B	OFF	ON	40	0.21
90	41	31%	92	31	211	A	OFF	ON	46	0.30

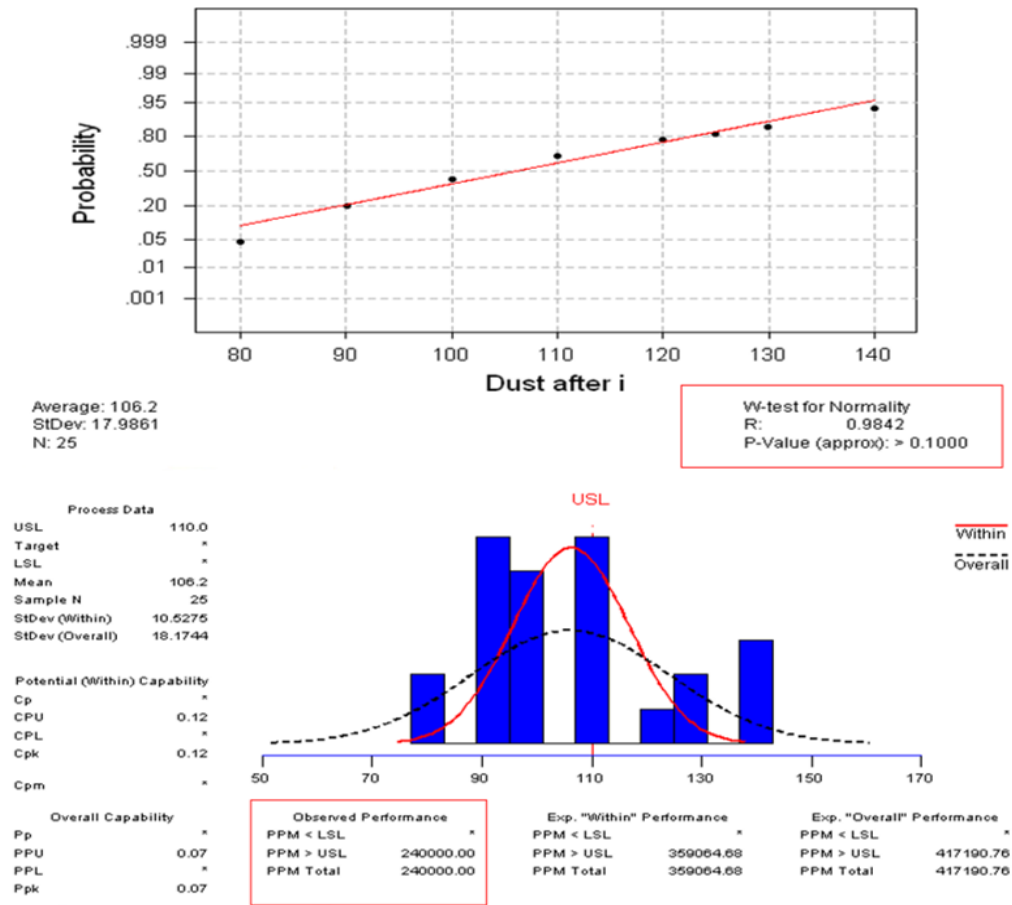

Figure 6: Statistical review of quantitative information of prilling dust after correction.

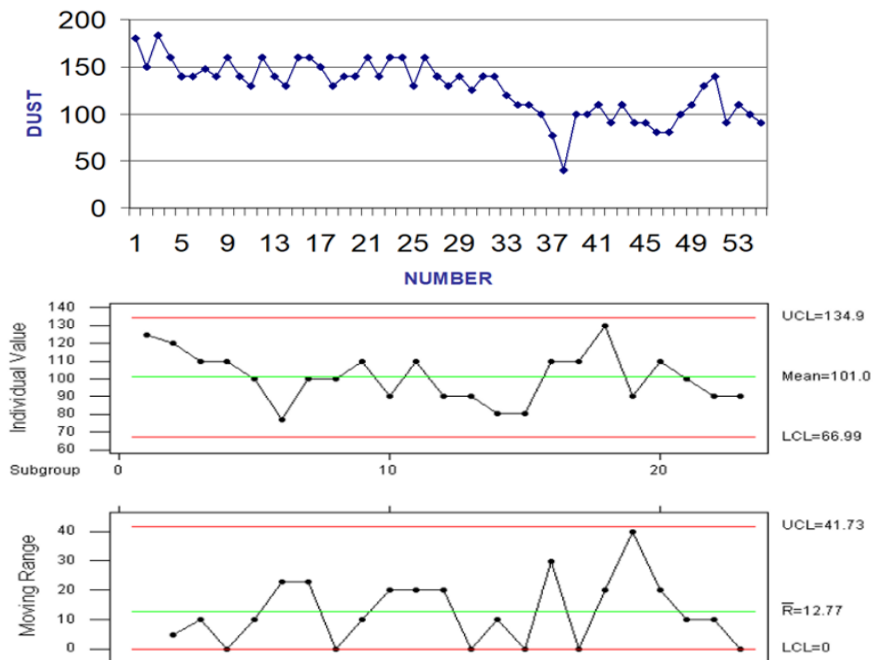

Figure 7: Control diagram of dust.

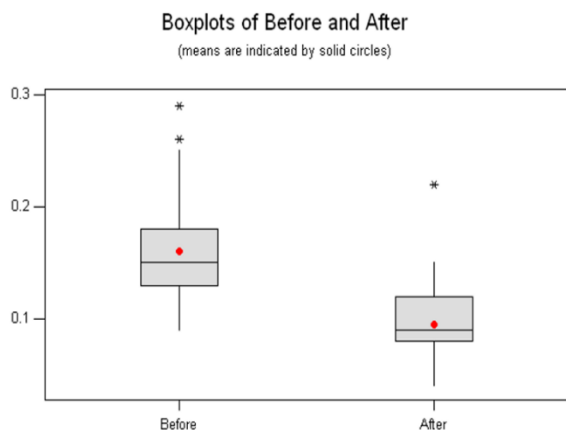

Fig. 8: Impact of the project on urea dust.

### Economic benefits from the implementation of reducing dust emission project

Since reducing dust is equal to reducing urea production, it preserves the capital of the urea production process. Reducing the urea dust from  $178 \text{ mg/Nm}^3$  to  $110 \text{ mg/Nm}^3$  according to the following equation will save money by 2,100,000,000 Rial per year:

Financial savings = [(The difference in the amount of dust output before and after the implementation of the plan) \* (The total out airflow from the top of the tower's fans) / 1000000] \* (The price of one kilogram of urea).

The issue of reducing dust in the outlet of the fan of the Prilling Tower is an environmental requirement [48]. The company must also pay the environmental fines if dust exceeds the specified allowable range. Today, due to the need to control the amount of dust in some similar units, dust recycling technology is used by the scrubber system, which the company has to pay much money to buy this technology. Exploitation operations, which include the workforce and materials used in this system, are also added to the company's costs. Therefore, doing this plan has reduced many costs for the company [49].

### CONCLUSIONS

Dust release into the environment causes environmental pollution and is considered a pollutant in environmental laws, and its control over urea units is mandatory [50, 51]. This study aimed to reduce urea dust and reduce the environmental impact of the

Khorasan Petrochemical Prilling Tower. The project was divided into six general phases (six Sigma) and implemented. This is a way to improve continuous quality by reducing the inherent changes in the process. The method used in this paper is DMAIC, a five-step improvement process such as definition, measurement, analysis, improvement, and control. By examining the effect of different factors and their change, the output dust of prilling fans was reduced from  $178 \text{ mg/Nm}^3$  to  $110 \text{ mg/Nm}^3$ , about 38.2%. According to quantitative criteria, choosing a solution to reduce the output dust based on execution risk, side effects on the process, simplicity of the solution, speed of response, no need for new equipment and devices, effectiveness, and execution cost. Reducing the output dust from the Prilling Tower was done by adjusting the output flow of the P-4140 pump, the slow discharge of the D-4120 drum, controlling the bucket SR-4101 A/B speed (Reduce from 245 to 206 rpm with periodic control), and adjusting it with the molten urea feed rate, reducing the level of molten urea in the urea storage tank, reducing the water in output urea of the second stage evaporator, adjusting the evaporator vacuum and also the minimization of condensation during discharge. The bucket speed factor (SR-4101) is the only factor without effect on the amount of dust presented in Table 3. According to the results of statistical data, low R-Sq and P-value in each parameter indicates the effectiveness of the model used. The nature of the industrial unit is such that one factor alone cannot be the ultimate influence, so that the set of factors will affect the amount of dust coming out of the fans of the Prilling Tower. Fig. 8 shows the impact of the model. Reducing the amount of dust in the urea product increases the quality and reduces the problems of urea clotting in the product warehouses. Reducing dust reduces the stickiness of urea grains and clumps, thus increasing the quality of the product, increasing sales and exports. Financial savings for 2,100,000,000 Rials per year were achieved due to the prevention of urea production in the form of dust (Reducing the amount of dust will increase product production, which will increase the company's revenue). The implementation of this activity has not incurred any special costs for the company and is only free research work. Presenting this activity to other similar units can be used as an experience.

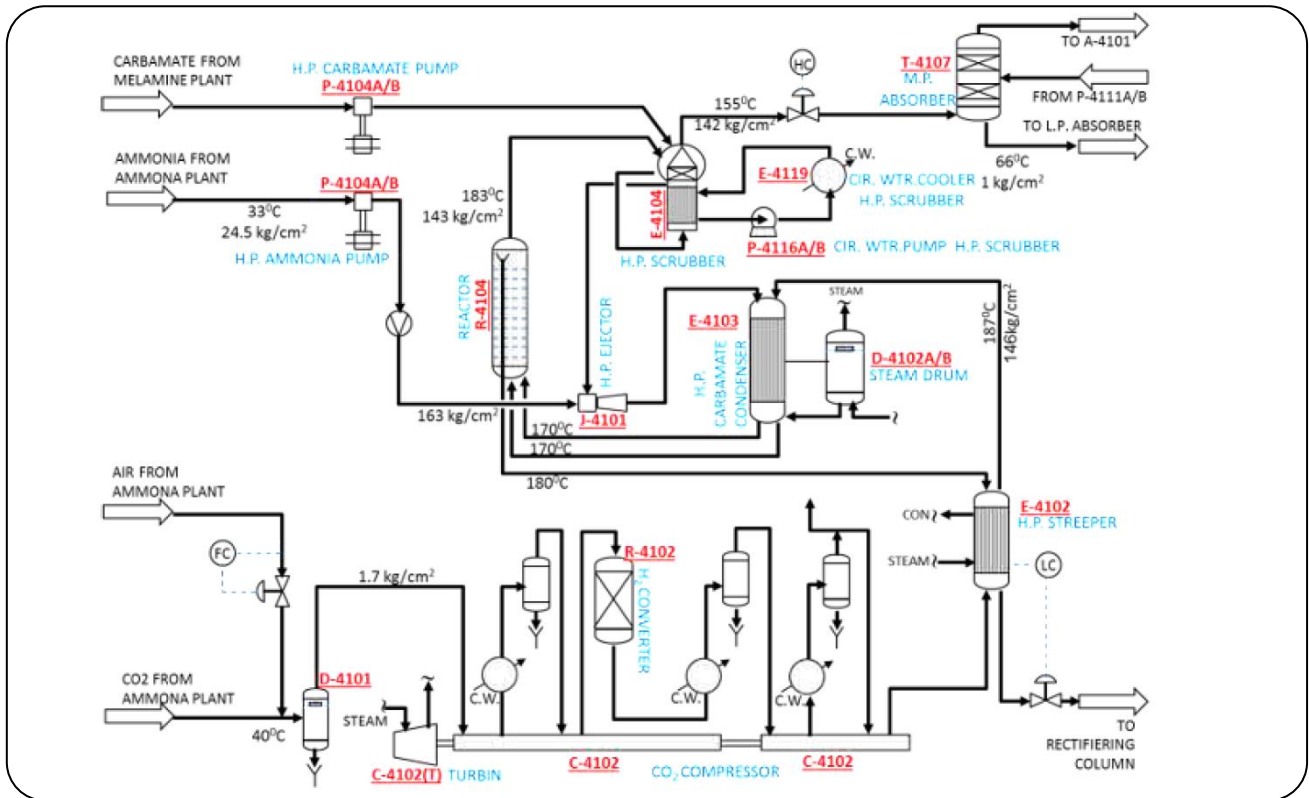

Fig. 9: The flow diagram of the synthesis section of the urea unit.

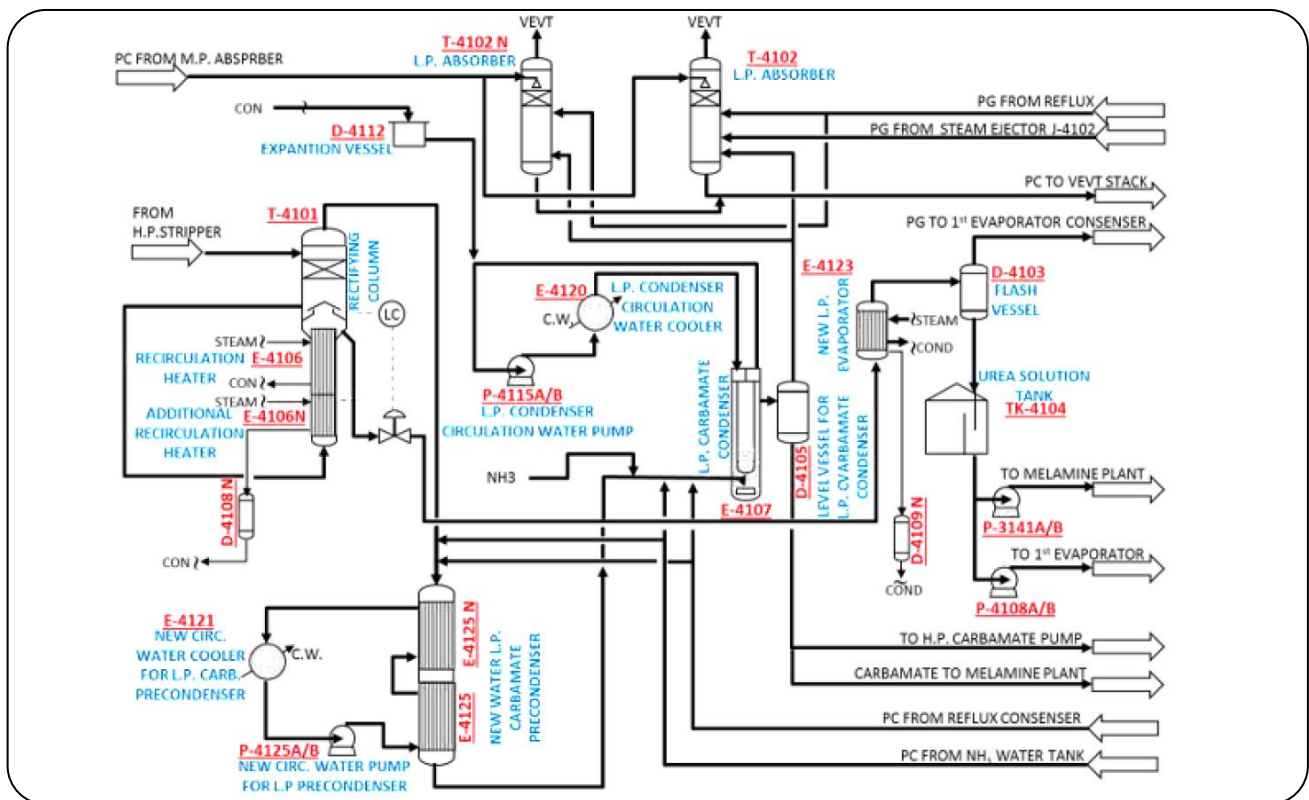

Fig. 10: General diagram of the return section and low-pressure carbamate.



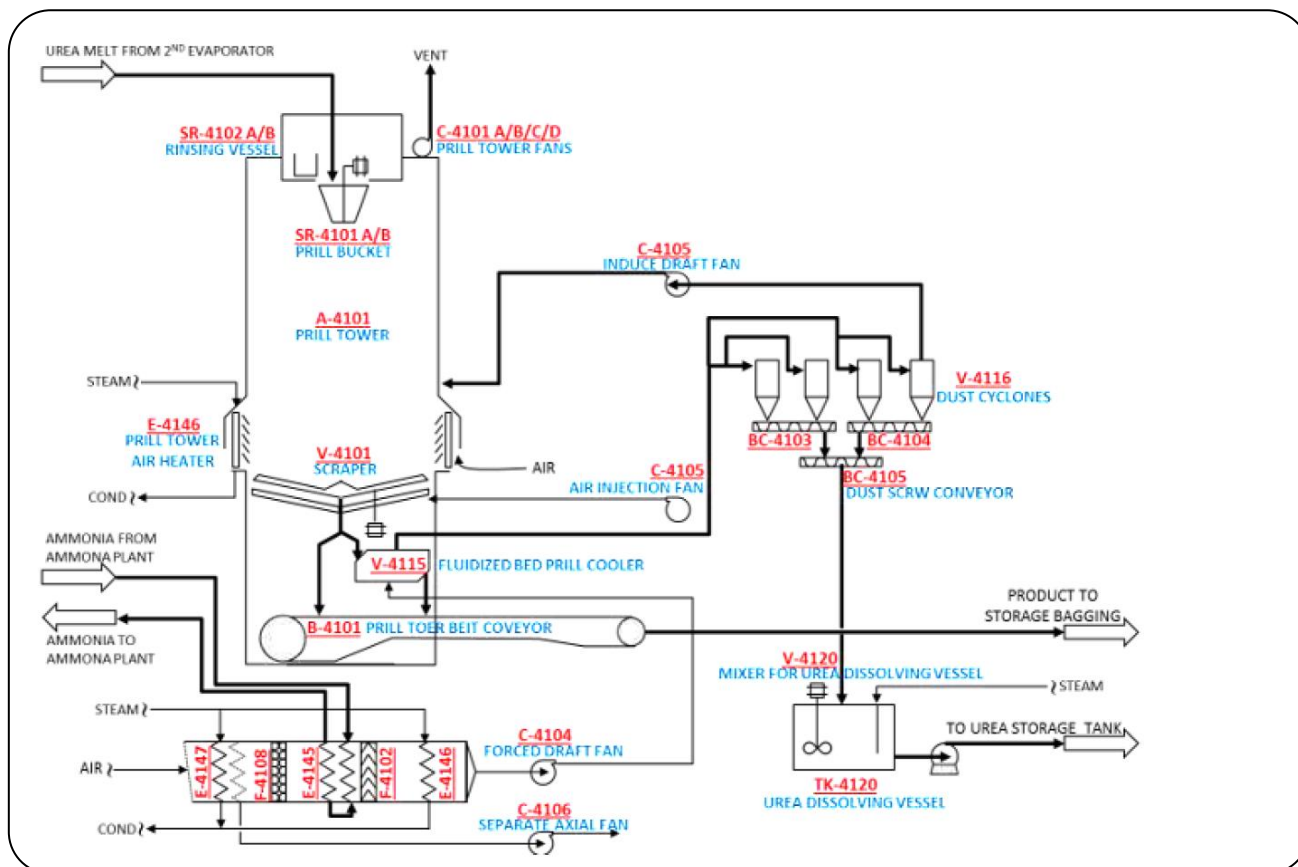

Fig. 11: The flow diagram of the prill tower of the urea unit.

Received : Oct. 27, 2021 ; Accepted : Feb. 14, 2022

## REFERENCES

- [1] Azhar N.A.L., Rani S.I., *Experimental Study of Airborne Dust Generation during Power Free Falling*, *Acta Mech. Malaysia.*, **3**: 37–39 (2020).
- [2] Cotabarren I.M., Bertin D.E., Sussy XimenaIcon V.M., Mirazú L.A., Piia J., Bucala V., "Production of Granular Urea as Nitrogenous Fertiliser - An Overview", Nova Science Publishers (2014).
- [3] Ahsan S., "Neem Coated Urea: A Fiscal Approach for Farmers," *AIChE Annual Meeting* (2017).
- [4] Moradi S., Shayesteh K., Lotfiman S., *The Modelling of the Urea Fertilizer Dissolution Process in Finite/Infinite Volumes of Water*. *Iran. J. Chem. Chem. Eng. (IJCCE)*, **41(4)**: 1348-1359 (2022).
- [5] Gilbert P.M., Harrison J., Heil C., Seitzinger S., *Escalating Worldwide use of Urea - A Global Change Contributing to Coastal Eutrophication*, *Biogeochemistry*, **77**: 441–463 (2006).
- [6] Guo X., Zhang R., Zhang L., Yan J., *Preparation of Solid Superacid SO<sub>4</sub><sup>2-</sup>/ZnO-TiO<sub>2</sub> and Its Action on Synthesis of Dimethyl Carbonate from Urea and Methanol*, *Iran. J. Chem. Chem. Eng. (IJCCE)*, **32(3)**: 69-74 (2013).
- [7] Haghigat P.H., Torabi A.M., *Preparation of Biodegradable Low Density Polyethylene by Starch-Urea Composition for Agricultural Applications*, *Iran. J. Chem. Chem. Eng. (IJCCE)*, **23(1)**: 7-11 (2004).
- [8] Khajavi M.S., Dakamin M.G., Hazarkhani H., Hajihadi M., Nikpour F., *An Efficient One Pot Procedure for Preparation of Symmetrical N,N'-Disubstituted Urea from Aromatic and Aliphatic Amines and Urea under Microwave Irradiation*, *Iran. J. Chem. Chem. Eng. (IJCCE)*, **19(1)**: 24-28 (2000).
- [9] Rahmanian N., Ghadiri M., "High Intensity Mixer," *European Patent Application EP 0885 652 A1.3* (2011).
- [10] Rahmanian N., Ghadiri M., Jia X., *Seeded Granulation*, *Powder Technol.*, **206**: 53-62 (2011).

- [11] Rahmanian N., Homayoonfard M., Alamdari A., [Simulation of Urea Prilling Process: An Industrial Case Study](#), *Chem. Eng. Commun.*, **200**: 764-782 (2013).
- [12] Couper J.R., Penney W.R., Fair J.R., Walas S.M., ["Chemical Process Equipment,"](#) 2nd ed., Elsevier (2004).
- [13] Panjehshahi M.H., Ataei A., Gharaei M., [A Comprehensive Approach to an Optimum Design and Simulation Model of a Mechanical Draft Wet Cooling Tower](#), *Iran. J. Chem. Chem. Eng. (IJCCE)*, **29**(1): 21-32 (2010).
- [14] Willems M.H., Klok J.W., ["Method for Making Urea Prills and Urea Prills Obtained by Applying this Method,"](#) Applying This Method 75 Inventors (1981).
- [15] Lee T., Chen J.W., Lee H.L., Lin T.Y., Tsai Y.C., Cheng S.L., Lee S.W., Hu J.C., Chen L.T., [Stabilization and Spheroidization of Ammonium Nitrate: Co-Crystallization with Crown Ethers and Spherical Crystallization by Solvent Screening](#), *Chem. Eng. J.*, **225**: 809–817 (2013).
- [16] Gezerman A.O., [A Practical Solution to Abate Emission of Ammonium Nitrate and Ammonia during Prilling and Granulation Processes](#), *Int. J. Mod. Chem.*, **2012**: 57–63 (2012).
- [17] Saleh S.N., Ahmed S.M., Al-mosuli D., Barghi S., [Basic design Methodology for a Prilling Tower](#), *Can. J. Chem. Eng.*, **93**: 1403–1409 (2015).
- [18] Skydanenko M., Sklabinskyi V., Saleh S., Barghi S., [Reduction of Dust Emission by Monodisperse System Technology for Ammonium Nitrate Manufacturing](#), *Processes*, **5**: 37 (2017).
- [19] Driver J.G., Owen R.E., Makanyire T., Lake J.A., McGregor J., Styring P., [Blue Urea: Fertilizer with Reduced Environmental Impact](#), *Front. Energy Res.*, **7**: 88 (2019).
- [20] da Costa T.P., Westphalen G., Nora F.B.D., de Zorzi Silva B., da Rosa G.S., [Technical and Environmental Assessment of Coated Urea Production with a Natural Polymeric Suspension in Spouted Bed to Reduce Nitrogen Losses](#), *J. Clean. Prod.*, **222**: 324–334 (2019).
- [21] Sakata E., Yanagawa T., [Latest Urea Technology for Improving Performance and Product Quality](#), Technology & Knowledge Research Centre, Tokyo Engineering Corporation, Japan (2002).
- [22] Wang S., Wang J., Song C., Wen J., [Numerical Investigation on Urea Particle Removal in a Spray Scrubber Using Particle Capture Theory](#), *Chem. Eng. Res. Des.*, **145**: 150–158 (2019).
- [23] Costa L.B., Godinho Filho M., Fredendall L.D., Ganga G.M., [Lean Six Sigma in the Food Industry: Construct Development and Measurement Validation](#), *Int. J. Prod. Econ.*, **231**: 107843 (2021).
- [24] Tucci H.N., de Oliveira Neto G.C., Rodrigues F.L., Giannetti B.F., de Almeida C.M., [Six Sigma with the Blue Economy Fundamentals to Assess the Economic and Environmental Performance in the Aircraft Refueling Process](#), *Renew. Sust. Energ. Rev.*, **150**: 111424 (2021).
- [25] Wang H., Xin Z., Li Y., [Synthesis of Ureas from CO<sub>2</sub>](#), *Top. Curr. Chem.*, **375**: 1–26 (2017).
- [26] Saleh S.N., Barghi S., [Reduction of Fine Particle Emission from a Prilling Tower using CFD Simulation](#), *Chem. Eng. Res. Des.*, **109**: 171–179 (2016).
- [27] Irshad U., Sharif M.N., Rabbani F., Rauf A., Saleem M., [Experimental Study of Urea Granulation](#), *Nucl.*, **46**: 95–99 (2020).
- [28] Kumar S., Satsangi P., Prajapati D., [Six Sigma an Excellent Tool for Process Improvement - A Case Study](#), *Int. J. Sci. Eng. Res.*, **2**: 1-10 (2011).
- [29] Smełkowska M., Mrugalska B., [Using Six Sigma DMAIC to Improve the Quality of the Production Process: A Case Study](#), *Procedia - Soc. Behav. Sci.*, **238**: 590–596 (2018).
- [30] Priya Swami A., Bhagyashree Kadiwal A., Professor A., [Implementation of Six Sigma Methodology in Construction Industry for Quality Process Improvement](#), *Int. Res. J. Eng. Technol.*, **7**(4): 4285-4290 (2020).
- [31] Graafmans T., Turetken O., Poppelaars H., Fahland D., [Process Mining for Six Sigma](#), *Bus. Inf. Syst. Eng.*, **63**: 277-300 (2021).
- [32] Prashar A., [Adopting Six Sigma DMAIC for Environmental Considerations in Process Industry Environment](#), *TQM J.*, **32**: 1241–1261 (2020).
- [33] Sharma P., Malik S.C., Gupta A., Jha P.C., [A DMAIC Six Sigma Approach to Quality Improvement in the Anodising Stage of the Amplifier Production Process](#), *Int. J. Qual. Reliab. Manag.*, **35**: 1868–1880 (2018).

- [34] Baboo P., [Energy Saving and Dust Management in Urea Bagging Plant](#), *Int. J. Eng. Res.*, **7(2)**: 73-80 (2018).
- [35] P. Baboo, [Urea Product Quality](#), *Int. J. Eng. Res.*, **7(4)**: 103-111 (2018).
- [36] Ghourchian H., Moulai R.A., Elyasvandi H., [A Conductometric Urea Biosensor by Direct Immobilization of Urease on Pt Electrode](#), *Iran. J. Chem. Chem. Eng. (IJCCE)*, **23**: 55-63 (2004).
- [37] Saidi I., Ben Abdelmalek J., Ben Said O., Chicharo L., Beyrem H. [Chemical Composition and Heavy Metal Content of Portland Cement in Northern Tunisia](#), *Iran. J. Chem. Chem. Eng. (IJCCE)*, **39**: 147-158 (2020).
- [38] Nishikawa G., Yanagawa T., Morikawa H., Sakata E., Kojima Y., [Large Scale Urea Granulation Plants Based on TEC Technology](#) (2001).
- [39] Akhbarifar S., Shirvani M., Zahedi S., Zahiri M.R., Shamsaii Y., [Improving Cyclone Efficiency by Recycle and Jet Impingement Streams](#), *Iran. J. Chem. Chem. Eng. (IJCCE)*, **30(2)**: 119-124 (2011).
- [40] Cadena A.J., Brouwer M., " [Managing the Optimum Moisture Content -Key to Assure the Optimum Urea Product Quality](#)", Nitrogen & Syngas (2014).
- [41] Nguyen N.C., " [Best Available Techniques for Pollution Prevention and Control in the European Fertilizer Industry Booklet No. 4 of 8](#)", Production of Phosphoric Acid, 2000 EFMA European Fertilizer Manufacturers #39; Association, in: Prod. Phosphoric Acid (2000).
- [42] Skydanenko M., Sklabinskyi V., Nadhem A.K., Nichvolodin K., [Determination of Granule \(Prill\) Movement Modes in the Prilling Tower for Mineral Fertilizer Production](#), *Technol. Audit. Prod. Reserves*, **5**: 6-9 (2021).
- [43] Gopinath S., Devan P.K., [Optimization and Prediction of Reaction Parameters of Plastic Pyrolysis oil production using Taguchi Method](#), *Iran. J. Chem. Chem. Eng. (IJCCE)*, **39(2)**: 91-103 (2020).
- [44] Nonso U.C., Dominic O.O., Ifeanyi U.B., Faith O.O., Amaechi E.T., Madus E.P., [Methanolysis Optimization of Cottonseed Oil to Biodiesel Using Heterogeneous Catalysts](#), *Iran. J. Chem. Chem. Eng. (IJCCE)*, **39(4)**: 355-370 (2020).
- [45] Dash S.K., Parmar K.K., Padmavathi G.K., [Multiple Objective Optimization of Industrial Naphtha Cracking Process by Box-Behnken Response Surface Methodology](#), *Iran. J. Chem. Chem. Eng. (IJCCE)*, **41(9)**: 3223-3243 (2021).
- [46] Moradi S, Shayesteh K, Lotfiman S. [The Modelling of the Urea Fertilizer Dissolution Process in Finite/Infinite Volumes of Water](#), *Iran. J. Chem. Chem. Eng. (IJCCE)*, **41(4)**: 1348-1359 (2021).
- [47] [Dust Emission of Prilling Towers - Ureaknowhow.com - Where the Urea-Industry Meets](#) (2010).  
<https://www.ureaknowhow.com/ukh2/library/441-2010-02-brouwer-ureaknowhowcom-dust-emission-of-prilling-towers.html> (accessed January 29, 2021).
- [48] Norouzi N., Choupanpiesheh S., Talebi S., Khajehpour H., [Exergoenvironmental and Exergoeconomic Modelling and Assessment in the Complex Energy Systems](#), *Iran. J. Chem. Chem. Eng. (IJCCE)*, **41(3)**: 989-1002 (2021).
- [49] Huber M.A., Moroniak-Wawryszuk D., Lata L., [Roughcast Analysis as a New Method of Environmental Research](#), *Iran. J. Chem. Chem. Eng. (IJCCE)*, **41(5)**: 1765-1785 (2021).
- [50] Gopinath S., Devan P.K., Pitchandi K., [Production of Pyrolytic Oil from ULDP Plastics using Silica-Alumina Catalyst and used as Fuel for DI Diesel Engine](#), *RSC Adv.*, **10**: 37266-37279 (2020).
- [51] Soundararajan G., Ponnusamy Kumarasami D., Chidambaranathan B., Kasi Viswanathan P., [Influence of Retarded Injection Timing on Thermal Performance and Emission Characteristics of a Diesel Engine Fuelled with an Optimized Pyrolytic Blend](#), *Energy Environ*, (2021).